

## ADS7066 Small, 8-Channel, 16-Bit, 250-kSPS SAR ADC With GPIOs

### 1 Features

- Small solution size:
  - 1.62-mm × 1.62-mm WCSP
  - Space-saving, capless, 2.5-V internal reference
- 8 channels configurable as any combination of:
  - Up to 8 analog inputs, digital inputs, or digital outputs
- Programmable averaging filters:
  - Programmable sample size for averaging
  - Averaging with internal conversions
  - 20-bit resolution for average output
- Low-leakage multiplexer with channel sequencer:
  - Manual mode
  - On-the-fly mode
  - Auto-sequence mode
- Excellent AC and DC performance:
  - SNR: 91.9 dB, THD: –100 dB
  - Improved SNR with programmable averaging filters
  - INL: ±1 LSB, 16-bit no missing codes
  - Internal calibration improves offset and drift
  - High sample rate with no latency output: 250 kSPS
- Wide operating range:
  - ADC input range: 0 V to  $V_{REF}$  and  $2 \times V_{REF}$
  - Analog supply: 3 V to 5.5 V
  - Digital supply: 1.65 V to 5.5 V
  - Temperature range: –40°C to +125°C
- Enhanced-SPI digital interface:
  - High-speed, 60-MHz SPI interface

### 2 Applications

- [Optical modules](#)
- [Optical line cards](#)
- [Multiparameter patient monitors](#)

### 3 Description

The ADS7066 is a small, 16-bit, 8-channel, high-precision successive-approximation register (SAR) analog-to-digital converter (ADC). The ADS7066 has an integrated capless reference and a reference buffer that helps reduce the overall solution size by requiring fewer external components. The wafer-level-chip-scale package and fewer external components make this device suitable for space-constrained applications. The device family includes the ADS7067 (800 kSPS) and the ADS7066 (250 kSPS) speed variants.

The ADS7066 features built-in offset calibration for improved accuracy over wide operating conditions of the system. The programmable averaging filters enable higher resolution measurement. The eight channels of the ADS7066 can be individually configured as analog inputs, digital inputs, or digital outputs that enable smaller system size and simplify circuit design for mixed signal feedback and digital control.

The enhanced-SPI enables the ADS7066 in achieving high throughput at lower clock speeds, thereby simplifying the board layout and lowering system cost. The ADS7066 features a cyclic redundancy check (CRC) for data read and write operations and the power-up configuration.

#### Device Information<sup>(1)</sup>

PART NAME	PACKAGE	BODY SIZE (NOM)
ADS7066	WCSP (16)	1.62 mm × 1.62 mm

(1) For all available packages, see the orderable addendum at the end of the datasheet.

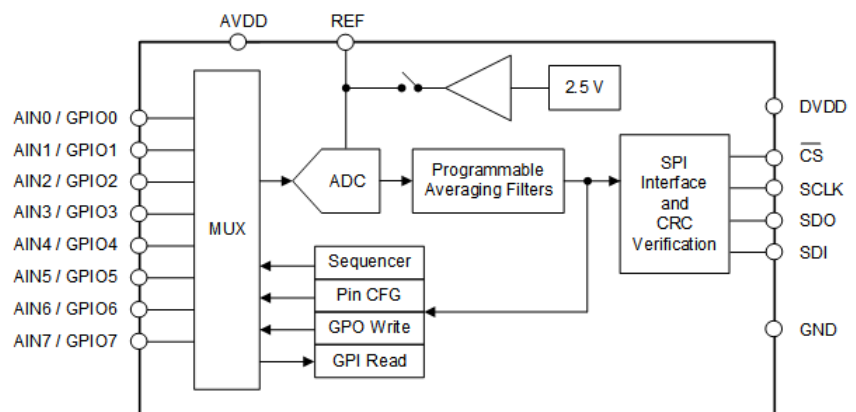

ADS7066 Block Diagram



## Table of Contents

<b>1 Features</b> .....	<b>1</b>	7.5 ADS7066 Registers.....	<b>28</b>
<b>2 Applications</b> .....	<b>1</b>	<b>8 Application and Implementation</b> .....	<b>35</b>
<b>3 Description</b> .....	<b>1</b>	8.1 Application Information.....	<b>35</b>
<b>4 Revision History</b> .....	<b>2</b>	8.2 Typical Application.....	<b>35</b>
<b>5 Pin Configuration and Functions</b> .....	<b>3</b>	<b>9 Power Supply Recommendations</b> .....	<b>37</b>
<b>6 Specifications</b> .....	<b>4</b>	9.1 AVDD and DVDD Supply Recommendations.....	<b>37</b>
6.1 Absolute Maximum Ratings .....	<b>4</b>	<b>10 Layout</b> .....	<b>38</b>
6.2 ESD Ratings .....	<b>4</b>	10.1 Layout Guidelines.....	<b>38</b>
6.3 Recommended Operating Conditions .....	<b>4</b>	10.2 Layout Example.....	<b>38</b>
6.4 Thermal Information .....	<b>5</b>	<b>11 Device and Documentation Support</b> .....	<b>39</b>
6.5 Electrical Characteristics .....	<b>6</b>	11.1 Device Support.....	<b>39</b>
6.6 Timing Requirements .....	<b>7</b>	11.2 Documentation Support.....	<b>39</b>
6.7 Switching Characteristics .....	<b>7</b>	11.3 Receiving Notification of Documentation Updates..	<b>39</b>
6.8 Timing Diagrams.....	<b>8</b>	11.4 Support Resources.....	<b>39</b>
6.9 Typical Characteristics.....	<b>9</b>	11.5 Trademarks.....	<b>39</b>
<b>7 Detailed Description</b> .....	<b>13</b>	11.6 Electrostatic Discharge Caution.....	<b>39</b>
7.1 Overview.....	<b>13</b>	11.7 Glossary.....	<b>39</b>
7.2 Functional Block Diagram.....	<b>13</b>	<b>12 Mechanical, Packaging, and Orderable</b>	
7.3 Feature Description.....	<b>13</b>	<b>Information</b> .....	<b>39</b>
7.4 Device Functional Modes.....	<b>25</b>		

## 4 Revision History

NOTE: Page numbers for previous revisions may differ from page numbers in the current version.

<b>Changes from Revision * (February 2020) to Revision A (June 2020)</b>	<b>Page</b>
• Changed document status from advance information to production data .....	<b>1</b>

## 5 Pin Configuration and Functions

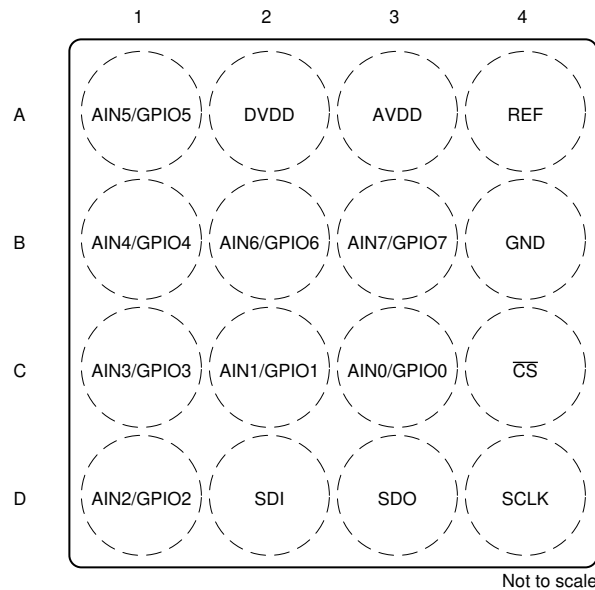

**Figure 5-1. YBH Package, 16-Pin WCSP, Top View**

**Table 5-1. Pin Functions**

PIN		FUNCTION <sup>(1)</sup>	DESCRIPTION
NO.	NAME		
A1	AIN5/GPIO5	AI, DI, DO	Channel 5; configurable as either an analog input (default) or general-purpose input/output (GPIO).
A2	DVDD	P	Digital I/O supply voltage. Connect a 1- $\mu$ F capacitor to GND.
A3	AVDD	P	Analog supply voltage. Connect a 1- $\mu$ F capacitor to GND.
A4	REF	P	Internal reference buffer output; external reference input. Connect a 1- $\mu$ F capacitor to GND.
B1	AIN4/GPIO4	AI, DI, DO	Channel 4; configurable as either an analog input (default) or GPIO.
B2	AIN6/GPIO6	AI, DI, DO	Channel 6; configurable as either an analog input (default) or GPIO.
B3	AIN7/GPIO7	AI, DI, DO	Channel 7; configurable as either an analog input (default) or GPIO.
B4	GND	P	Ground for power supply, all analog and digital signals are referred to this pin.
C1	AIN3/GPIO3	AI, DI, DO	Channel 3; configurable as either an analog input (default) or GPIO.
C2	AIN1/GPIO1	AI, DI, DO	Channel 1; configurable as either an analog input (default) or GPIO.
C3	AIN0/GPIO0	AI, DI, DO	Channel 0; configurable as either an analog input (default) or GPIO.
C4	$\overline{CS}$	DI	Chip-select input pin; active low. The device takes control of the data bus when $\overline{CS}$ is low. The SDO pin goes to Hi-Z when $\overline{CS}$ is high.
D1	AIN2/GPIO2	AI, DI, DO	Channel 2; configurable as either an analog input (default) or GPIO.
D2	SDI	DI	Serial data input pin for SPI interface.
D3	SDO	DO	Serial data output pin for SPI interface.
D4	SCLK	DI	Clock input pin for the SPI interface.

(1) AI = analog input, DI = digital input, DO = digital output, P = power supply.

## 6 Specifications

### 6.1 Absolute Maximum Ratings

over operating ambient temperature range (unless otherwise noted)<sup>(1)</sup>

	MIN	MAX	UNIT
DVDD to GND	-0.3	5.5	V
AVDD to GND	-0.3	5.5	V
AINx/GPIOx <sup>(2)</sup> to GND	GND - 0.3	AVDD + 0.3	V
REF to GND	GND - 0.3	AVDD + 0.3	V
Digital inputs (CS, SDI, SCLK) to GND	GND - 0.3	5.5	V
Input current to any pin except supply pins <sup>(3)</sup>	-10	10	mA
Junction temperature, T <sub>J</sub>	-40	150	°C
Storage temperature, T <sub>stg</sub>	-60	150	°C

- (1) Stresses beyond those listed under *Absolute Maximum Rating* may cause permanent damage to the device. These are stress ratings only, which do not imply functional operation of the device at these or any other conditions beyond those indicated under *Recommended Operating Condition*. Exposure to absolute-maximum-rated conditions for extended periods may affect device reliability.
- (2) AINx/GPIOx refers to AIN0/GPIO0, AIN1/GPIO1, AIN2/GPIO2, AIN3/GPIO3, AIN4/GPIO4, AIN5/GPIO5, AIN6/GPIO6, and AIN7/GPIO7 pins.
- (3) Pin current must be limited to 10 mA or less.

### 6.2 ESD Ratings

		VALUE	UNIT
V <sub>(ESD)</sub>	Electrostatic discharge	Human body model (HBM), per ANSI/ESDA/ JEDEC JS-001, all pins <sup>(1)</sup>	V
		Charged device model (CDM), per JEDEC specification JESD22-C101, all pins <sup>(2)</sup>	

- (1) JEDEC document JEP155 states that 500-V HBM allows safe manufacturing with a standard ESD control process.
- (2) JEDEC document JEP157 states that 250-V CDM allows safe manufacturing with a standard ESD control process.

### 6.3 Recommended Operating Conditions

over operating free-air temperature range (unless otherwise noted)

PARAMETER		TEST CONDITIONS	MIN	TYP	MAX	UNIT
<b>POWER SUPPLY</b>						
AVDD	Analog power supply	AVDD to GND	3	3.3	5.5	V
DVDD	Digital power supply	DVDD to GND	1.65	3.3	5.5	V
<b>REFERENCE VOLTAGE</b>						
V <sub>REF</sub>	Reference voltage to the ADC	Internal reference	2.5		AVDD	V
		External reference	2.4			
<b>ANALOG INPUTS</b>						
FSR	Full-scale input range	RANGE = 0b	0		V <sub>REF</sub>	V
		RANGE = 1b	0		2 x V <sub>REF</sub>	
V <sub>IN</sub>	Absolute input voltage	AINx <sup>(1)</sup> to GND	-0.1		AVDD + 0.1	V
<b>TEMPERATURE RANGE</b>						
T <sub>A</sub>	Ambient temperature		-40	25	125	°C

- (1) AINx refers to analog inputs AIN0, AIN1, AIN2, AIN3, AIN4, AIN5, AIN6, and AIN7.

## 6.4 Thermal Information

THERMAL METRIC <sup>(1)</sup>		ADS7066	UNIT
		YBH (WCSP)	
		16 PINS	
$R_{\theta JA}$	Junction-to-ambient thermal resistance	80.2	°C/W
$R_{\theta JC(top)}$	Junction-to-case (top) thermal resistance	0.4	°C/W
$R_{\theta JB}$	Junction-to-board thermal resistance	18.8	°C/W
$\Psi_{JT}$	Junction-to-top characterization parameter	0.2	°C/W
$\Psi_{JB}$	Junction-to-board characterization parameter	18.8	°C/W

- (1) For more information about traditional and new thermal metrics, see the [Semiconductor and IC Package Thermal Metrics](#) application report.

## 6.5 Electrical Characteristics

at AVDD = 3 V to 5.5 V, DVDD = 1.65 V to 5.5 V, VREF = 2.5 V (internal), and maximum throughput (unless otherwise noted); minimum and maximum values at TA = -40°C to +125°C; typical values at TA = 25°C.

PARAMETER		TEST CONDITIONS	MIN	TYP	MAX	UNIT
<b>ANALOG INPUTS</b>						
CIN	Input capacitance	ADC and MUX capacitance		30		pF
<b>DC PERFORMANCE</b>						
	Resolution	No missing codes		16		Bits
DNL	Differential nonlinearity		-0.75	±0.4	0.75	LSB
INL	Integral nonlinearity		-4	±1	4	LSB
V(OS)	Input offset error	Post offset calibration, OSR[2:0] = 7	-7	±0.5	7	LSB
dVOS/dT	Input offset thermal drift	Post offset calibration, OSR[2:0] = 7		±0.6		ppm/°C
	Offset error match	OSR[2:0] = 7	-2.75	0.5	2.75	LSB
GE	Gain error <sup>(1)</sup>	External VREF = 2.5 V, OSR[2:0] = 7	-0.05	±0.01	0.05	%FSR
dGE/dT	Gain error thermal drift	External VREF = 2.5 V, OSR[2:0] = 7		±0.5		ppm/°C
	Gain error match	OSR[2:0] = 7	-0.005	±0.001	0.005	%FSR
<b>AC PERFORMANCE</b>						
SINAD	Signal-to-noise + distortion ratio	fIN = 2 kHz, VREF = 2.5V (internal)		86.5		dB
		fIN = 2 kHz, VREF = 5 V, AVDD = 5 V	88.75	91		
SNR	Signal-to-noise ratio	fIN = 2 kHz, VREF = 2.5V (internal)		86.8		dB
		fIN = 2 kHz, VREF = 5 V, AVDD = 5 V	90	91.9		
THD	Total harmonic distortion	fIN = 2 kHz		-100		dB
SFDR	Spurious-free dynamic range	fIN = 2 kHz		101		dB
	Isolation crosstalk	fIN = 10 kHz		-110		dB
<b>REFERENCE</b>						
VREF	Internal reference output voltage <sup>(3)</sup>	at TA= 25°C	2.497	2.5	2.503	V
dVREF/dT	Internal reference voltage temperature drift			6	19	ppm/°C
CREF	Decoupling capacitor at REF pin		1		10	µF
<b>DIGITAL INPUTS</b>						
VIL	Input low logic level	For CS, SCLK and SDI pins	-0.3	0.3 DVDD		V
		For GPIOX <sup>(2)</sup> pins	-0.3	0.3 AVDD		
VIH	Input high logic level	For CS, SCLK and SDI pins	0.7 DVDD	DVDD		V
		For GPIOX pins	0.7 AVDD	AVDD		
<b>DIGITAL OUTPUTS</b>						
VOL	Output low logic level	For SDO pin, IOL = 500 µA sink	0	0.2 DVDD		V
		For GPIOX <sup>(2)</sup> pins, IOL = 500 µA sink	0	0.2 AVDD		
VOH	Output high logic level	For SDO pin, IOH = 500 µA source	0.8 DVDD	DVDD		V
		For GPIOX <sup>(2)</sup> pins, IOH = 500 µA source	0.8 AVDD	AVDD		
<b>POWER SUPPLY</b>						
IAVDD	Analog supply current	AVDD = 3.3 V, external reference		0.7	0.91	mA
		AVDD = 3.3 V, internal reference		1.2	1.56	mA
		No conversion, external reference		250		µA
		No conversion, internal reference		800		µA

(1) These specifications include full temperature range variation but not the error contribution from internal reference.

(2) GPIOX refers to GPIO0, GPIO1, GPIO2, GPIO3, GPIO4, GPIO5, GPIO6, and GPIO7 pins.

(3) Does not include the variation in voltage resulting from solder shift effects.

## 6.6 Timing Requirements

at AVDD = 3 V to 5 V, DVDD = 1.65 V to 5.5 V, and maximum throughput (unless otherwise noted); minimum and maximum values at T<sub>A</sub> = –40°C to +125°C; typical values at T<sub>A</sub> = 25°C.

		MIN	MAX	UNIT
<b>CONVERSION CYCLE</b>				
f <sub>CYCLE</sub>	Sampling frequency		250	kSPS
t <sub>CYCLE</sub>	ADC cycle-time period	1/f <sub>CYCLE</sub>		s
t <sub>QUIET</sub>	Quiet acquisition time	20		ns
t <sub>ACQ</sub>	Acquisition time	Acquisition time	800	ns
t <sub>WH_CSZ</sub>	Pulse duration: $\overline{CS}$ high	220		ns
t <sub>WL_CSZ</sub>	Pulse duration: $\overline{CS}$ low	210		ns
<b>SPI INTERFACE TIMINGS</b>				
f <sub>CLK</sub>	Maximum SCLK frequency		60	MHz
t <sub>CLK</sub>	Minimum SCLK time period	16.67		ns
t <sub>PH_CK</sub>	SCLK high time	0.45	0.55	t <sub>CLK</sub>
t <sub>PL_CK</sub>	SCLK low time	0.45	0.55	t <sub>CLK</sub>
t <sub>SU_CSCK</sub>	Setup time: $\overline{CS}$ falling to the first SCLK capture edge	15		ns
t <sub>SU_CKDI</sub>	Setup time: SDI data valid to the SCLK capture edge	6.4		ns
t <sub>HT_CKDI</sub>	Hold time: SCLK capture edge to data valid on SDI	4		ns
t <sub>D_CKCS</sub>	Delay time: last SCLK falling to $\overline{CS}$ rising	0.8		ns

## 6.7 Switching Characteristics

at AVDD = 3 V to 5.5 V, DVDD = 1.65 V to 5.5 V, and maximum throughput (unless otherwise noted); minimum and maximum values at T<sub>A</sub> = –40°C to +125°C; typical values at T<sub>A</sub> = 25°C.

PARAMETER	TEST CONDITIONS	MIN	MAX	UNIT
<b>CONVERSION CYCLE</b>				
t <sub>CONV</sub>	ADC conversion time		3200	ns
<b>RESET</b>				
t <sub>PU</sub>	Power-up time for device	AVDD ≥ 3 V	5	ms
t <sub>RST</sub>	Delay time; RST bit = 1b to device reset complete <sup>(1)</sup>		5	ms
<b>SPI INTERFACE TIMINGS</b>				
t <sub>DEN_CSDO</sub>	Delay time: $\overline{CS}$ falling to data enable		22	ns
t <sub>DZ_CSDO</sub>	Delay time: $\overline{CS}$ rising to SDO going Hi-Z		50	ns
t <sub>D_CKDO</sub>	Delay time: SCLK launch edge to (next) data valid on SDO		16	ns

(1) RST bit is automatically reset to 0b after t<sub>RST</sub>.

## 6.8 Timing Diagrams

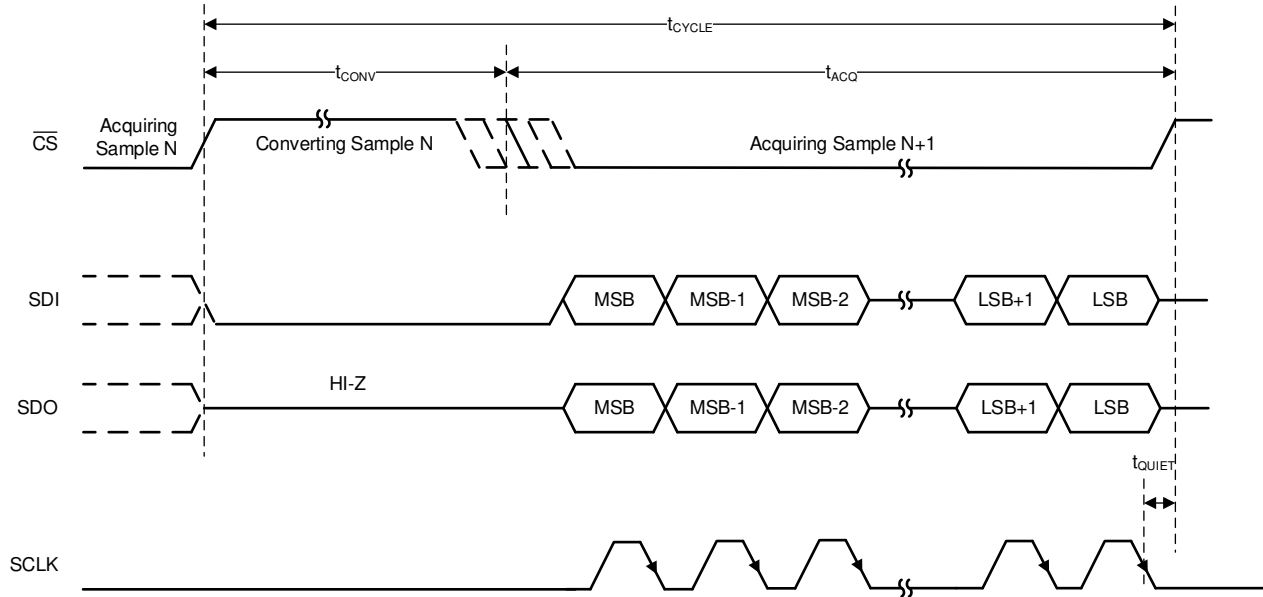

Figure 6-1. Conversion Cycle Timing

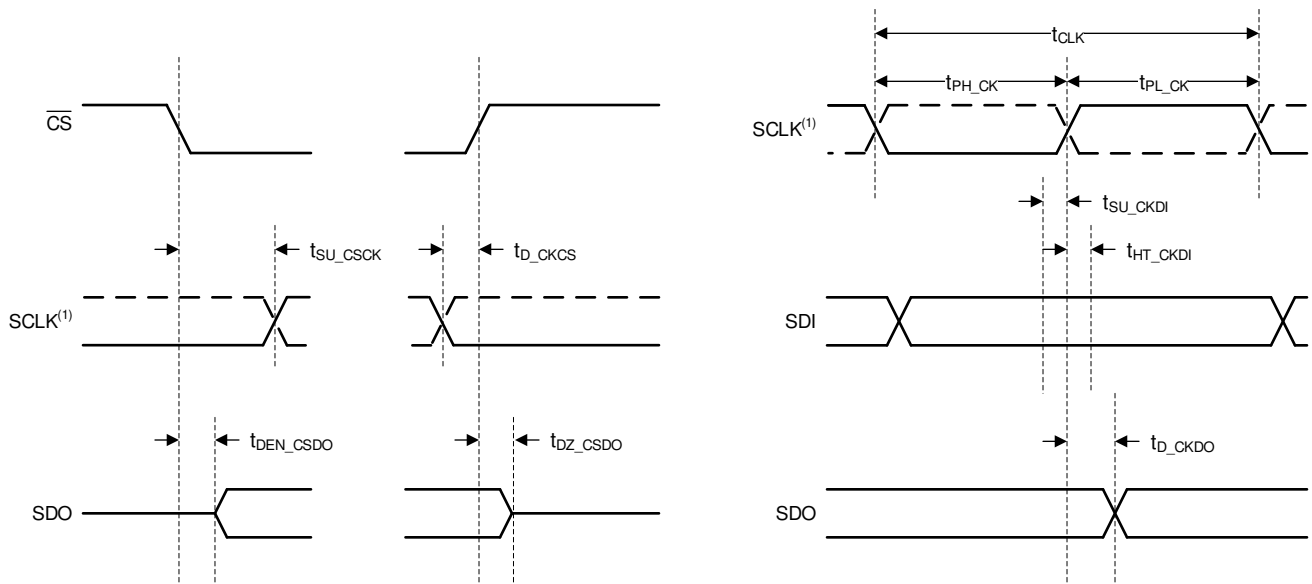
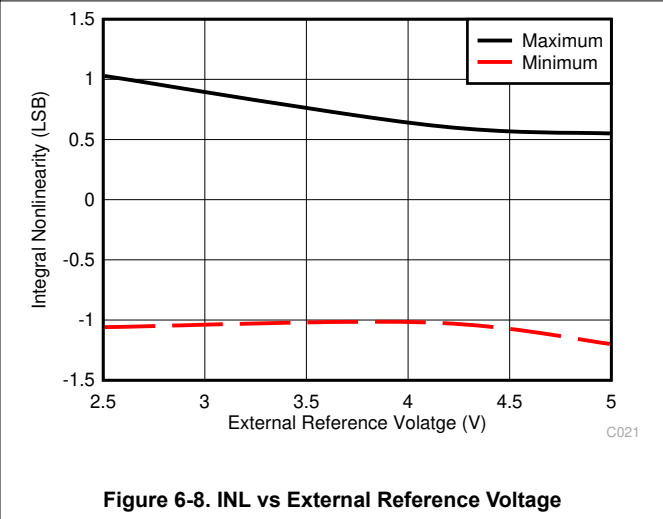
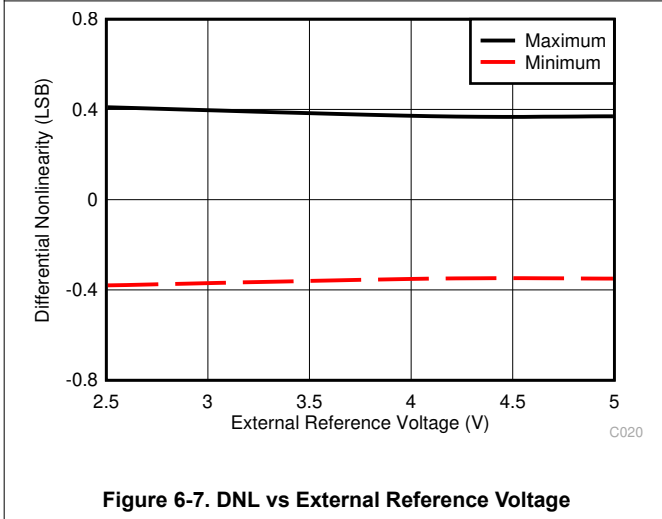
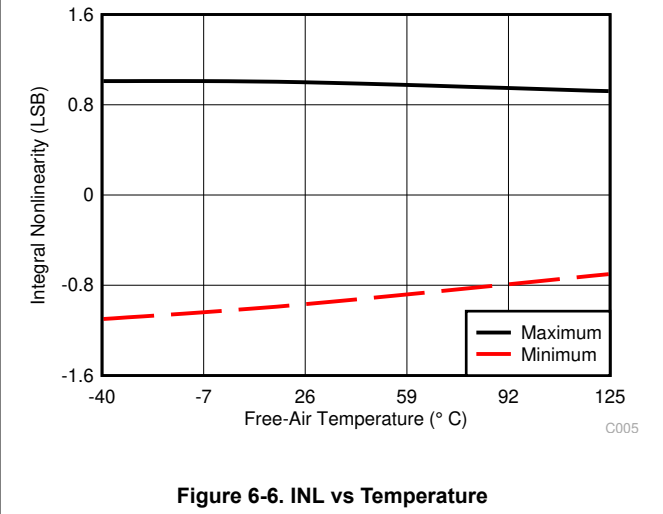
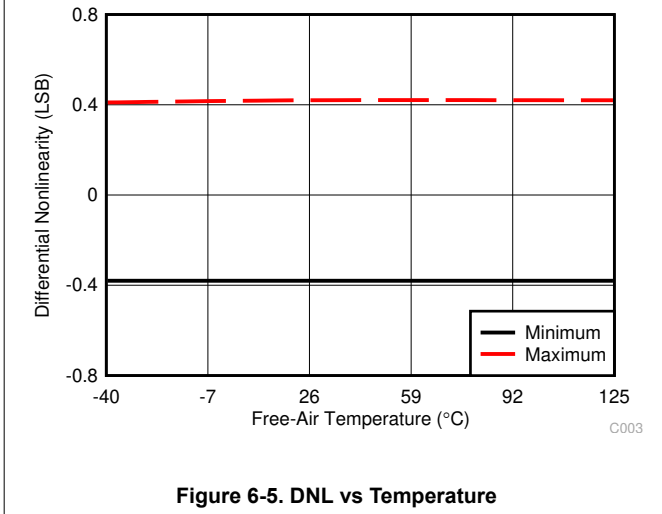
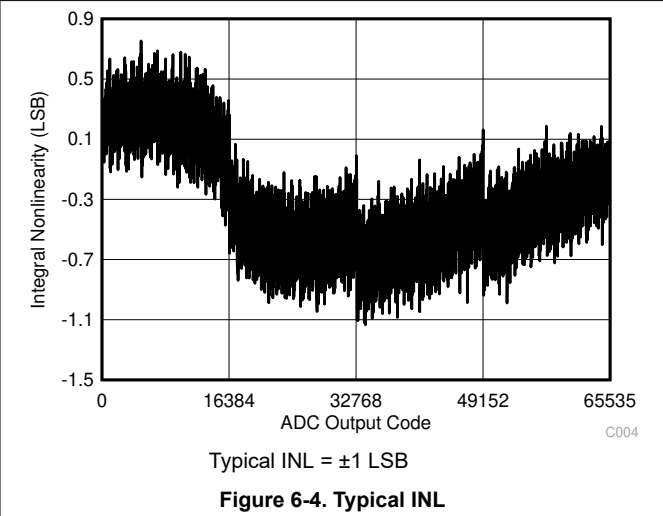
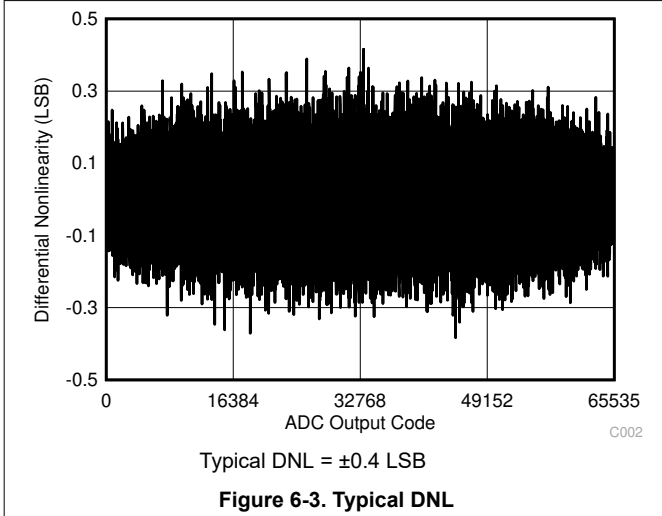

Figure 6-2. SPI Interface Timing

### 6.9 Typical Characteristics

at  $T_A = 25^\circ\text{C}$ ,  $AV_{DD} = 5\text{ V}$ ,  $DV_{DD} = 1.65\text{ V to }5.5\text{ V}$ , and maximum throughput (unless otherwise noted)



### 6.9 Typical Characteristics (continued)

at  $T_A = 25^\circ\text{C}$ ,  $AV_{DD} = 5\text{ V}$ ,  $DV_{DD} = 1.65\text{ V to }5.5\text{ V}$ , and maximum throughput (unless otherwise noted)

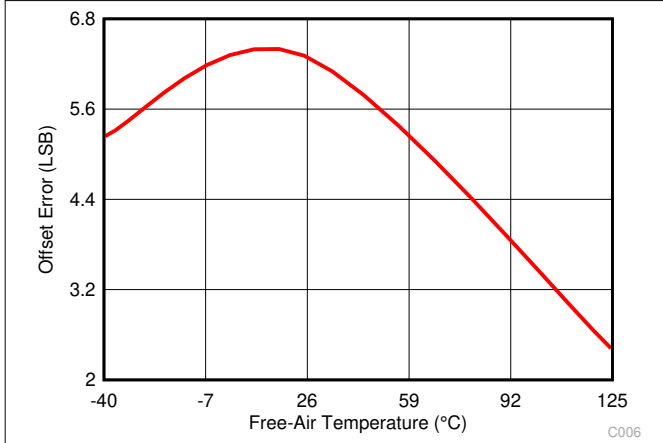

Figure 6-9. Offset Error vs Temperature

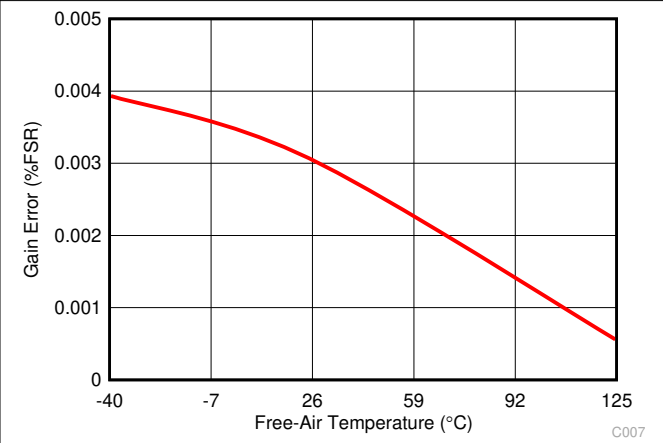

Figure 6-10. Gain Error vs Temperature

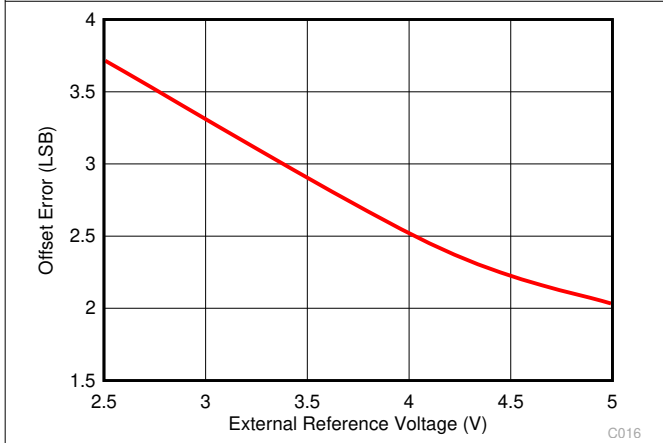

Figure 6-11. Offset Error vs External Reference Voltage

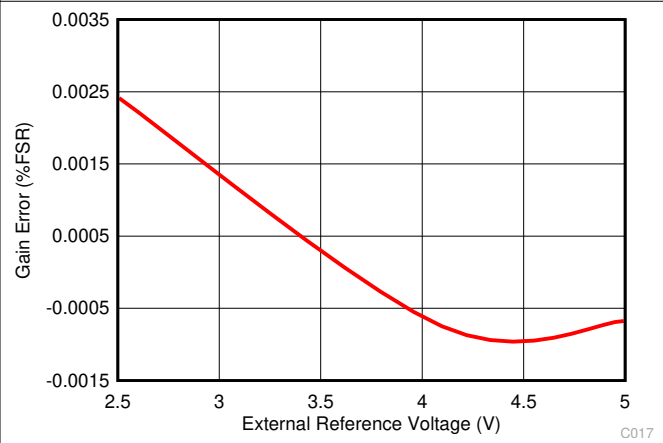

Figure 6-12. Gain Error vs External Reference Voltage

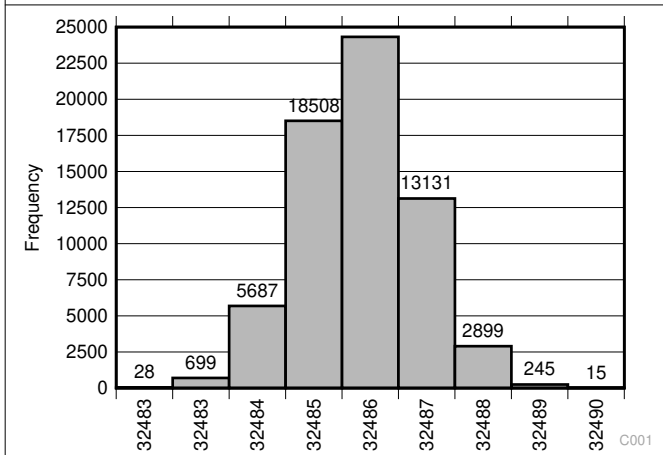

Figure 6-13. DC Input Histogram

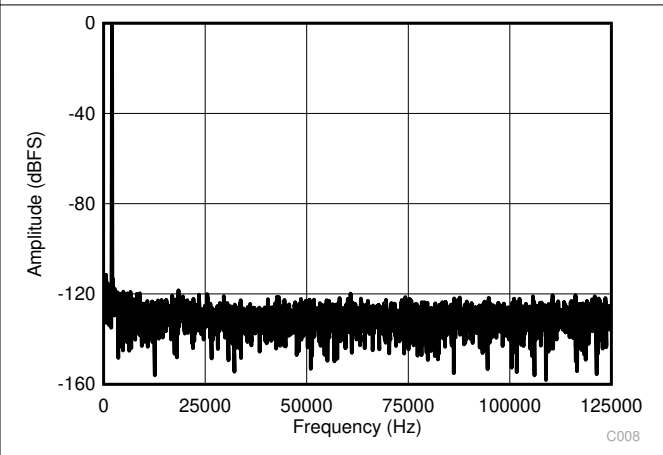

Figure 6-14. Typical FFT

## 6.9 Typical Characteristics (continued)

at  $T_A = 25^\circ\text{C}$ ,  $AVDD = 5\text{ V}$ ,  $DVDD = 1.65\text{ V to }5.5\text{ V}$ , and maximum throughput (unless otherwise noted)

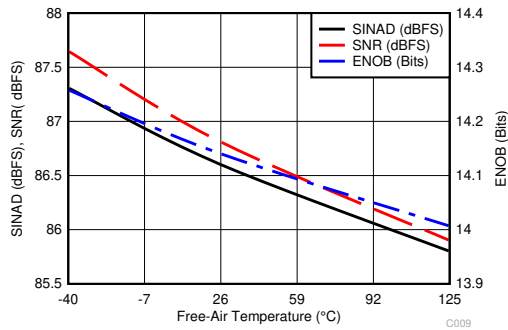

Figure 6-15. Noise Performance vs Temperature

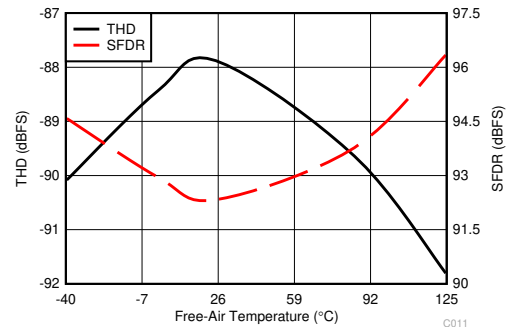

Figure 6-16. Distortion Performance vs Temperature

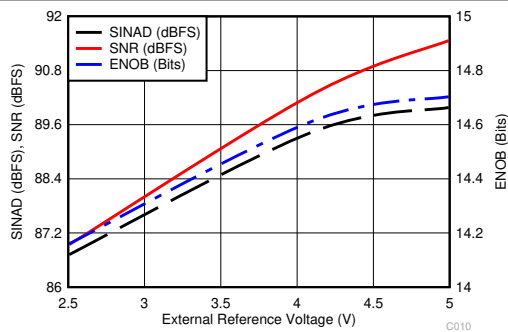

Figure 6-17. Noise Performance vs External Reference Voltage

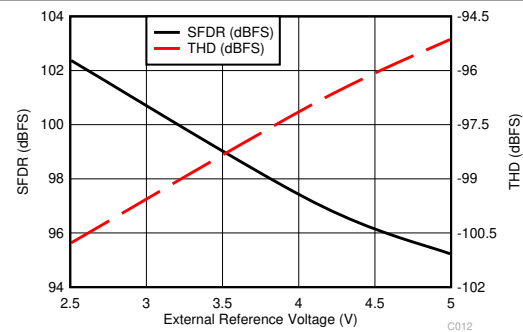

Figure 6-18. Distortion Performance vs External Reference Voltage

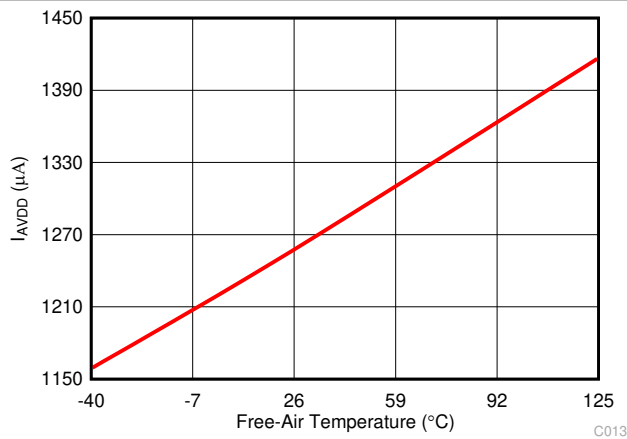

Figure 6-19. Analog Supply Current vs Temperature

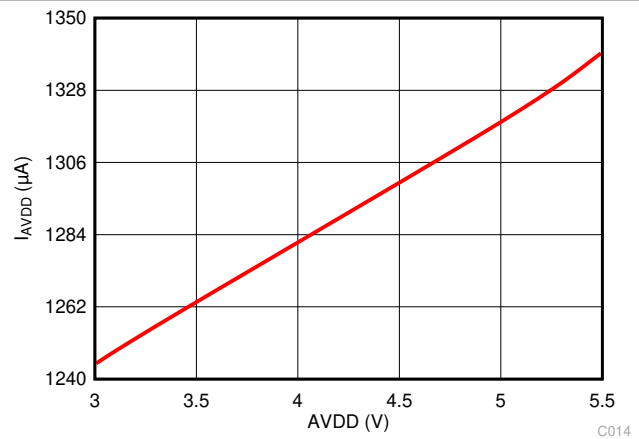
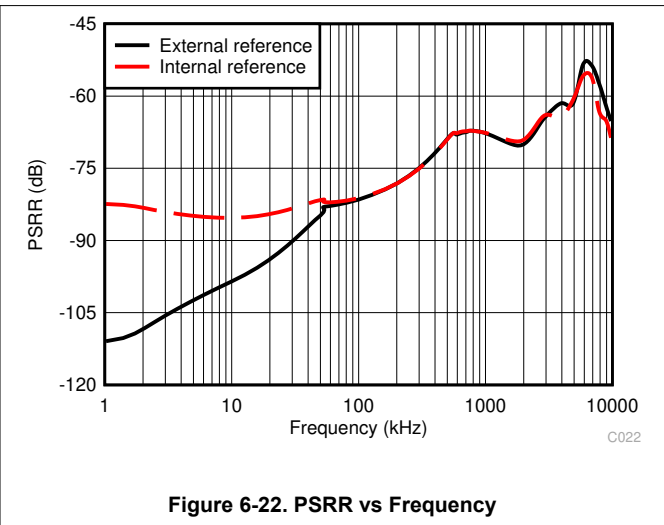
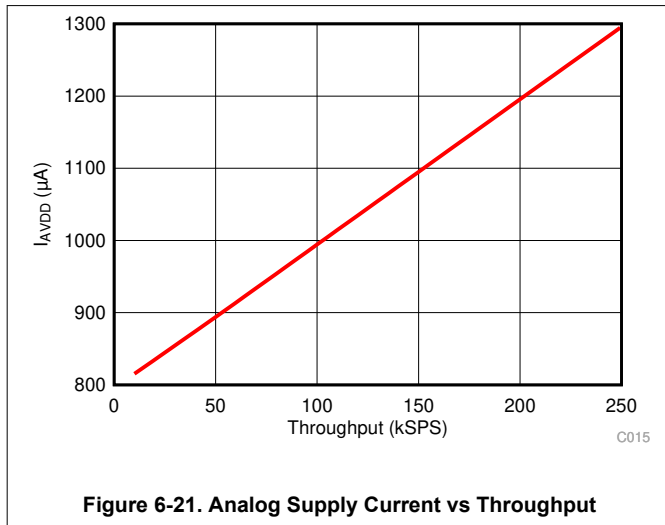

Figure 6-20. Analog Supply Current vs AVDD

### 6.9 Typical Characteristics (continued)

at  $T_A = 25^\circ\text{C}$ ,  $AVDD = 5\text{ V}$ ,  $DVDD = 1.65\text{ V to }5.5\text{ V}$ , and maximum throughput (unless otherwise noted)



## 7 Detailed Description

### 7.1 Overview

The ADS7066 is a 16-bit, successive approximation register (SAR) analog-to-digital converter (ADC) with an analog multiplexer. This device integrates a reference, reference buffer, low-dropout regulator (LDO), and features high performance at full throughput and low-power consumption.

The ADS7066 supports unipolar, single-ended analog input signals. The internal reference generates a low-drift, buffered, 2.5-V reference output. The device uses an internal clock to perform conversions. At the end of the conversion process, the device enters an acquisition phase.

### 7.2 Functional Block Diagram

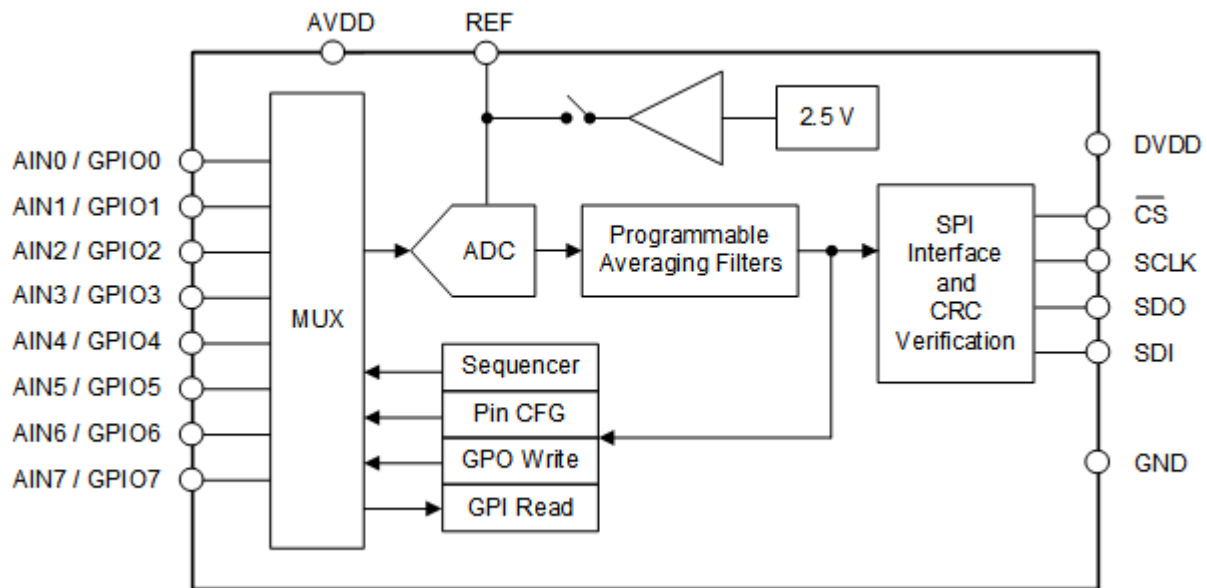

### 7.3.1 Analog Input and Multiplexer

The eight channels of the multiplexer can be independently configured as ADC inputs or general-purpose inputs/outputs (GPIOs). As shown in Figure 7-1, each input pin has ESD protection diodes to AVDD and GND. On power-up or after device reset, all eight channels of the multiplexer are configured as analog inputs.

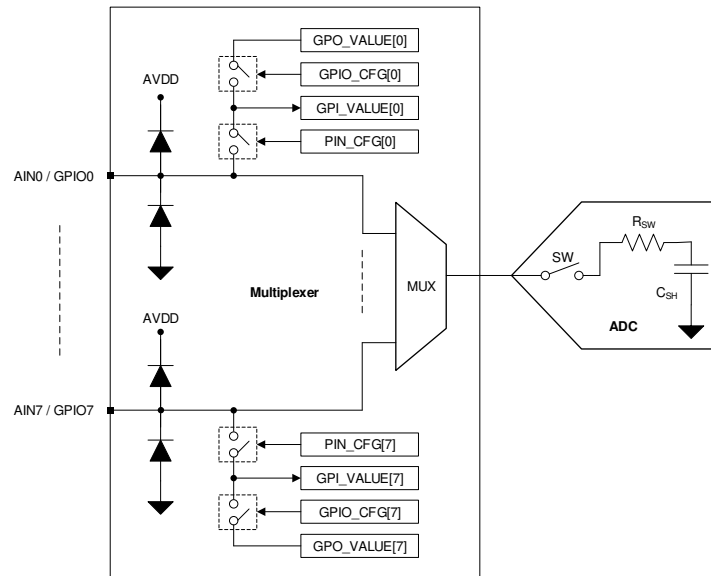

**Figure 7-1. Analog Inputs, GPIOs, and ADC Connections**

Figure 7-1 illustrates an equivalent circuit for the pins configured as analog inputs. The ADC sampling switch is represented by an ideal switch (SW) in series with a resistor ( $R_{SW}$ , typically 150  $\Omega$ ) and a sampling capacitor ( $C_{SH}$ , typically 30 pF). During acquisition, the SW switch is closed to allow the signal on the selected analog input channel to charge the internal sampling capacitor. During conversion, the SW switch is opened to disconnect the analog input channel from the sampling capacitor.

The multiplexer channels can be configured as GPIOs in the PIN\_CFG register. On power-up, all channels of the multiplexer are configured as analog inputs. The direction of a GPIO, input or output, can be set in the GPIO\_CFG register. The logic level of channels configured as digital inputs can be read from the GPI\_VALUE register. The digital outputs can be accessed by writing to the GPO\_VALUE register. The digital outputs can be configured as open-drain or push-pull in the GPO\_DRIVE\_CFG register.

### 7.3.2 Reference

The ADS7066 has a precision, low-drift voltage reference internal to the device.

#### 7.3.2.1 External Reference

External reference is the default configuration on power-up or after device reset. An external reference voltage source can be connected to the REF pin with an appropriate decoupling capacitor placed between the REF and GND pins. Best SNR is achieved with a 5-V external reference because the internal reference is limited to 2.5 V. For improved thermal drift performance, a reference from the REF60xx family ([REF6025](#), [REF6030](#), [REF6033](#), [REF6041](#), [REF6045](#), or [REF6050](#)) is recommended.

#### 7.3.2.2 Internal Reference

The device features an internal reference source with a nominal output value of 2.5 V. On power-up, the internal reference is disabled by default. To enable the internal reference, set EN\_REF = 1b in the GENERAL\_CFG register. A minimum 1- $\mu$ F decoupling capacitor is recommended to be placed between the REF and GND pins. The capacitor must be placed as close to the REF pin as possible. The REF pin has ESD protection diodes connected to the AVDD and GND pins.

When using internal reference, use AIN7/GPIO7 for measuring slow, varying, or DC signals to minimize coupling to the internal reference. Connect AIN7/GPIO7 to ground if this channel is unused.

### 7.3.3 ADC Transfer Function

The ADC output is in straight binary format. The full-scale input range (FSR) of the ADC is determined by the RANGE bit. On power-up, the FSR is 0 V to  $V_{REF}$ . When using the  $2 \times V_{REF}$  mode (RANGE = 1b), the ADC can measure analog inputs up to two times the voltage reference. [Equation 1](#) can be used to compute the ADC resolution:

$$1 \text{ LSB} = \text{FSR} / 2^N \quad (1)$$

where:

- FSR = Full-scale input range of the ADC
- N = 16

Figure 7-2 and Table 7-1 show the ideal transfer characteristics for this device.

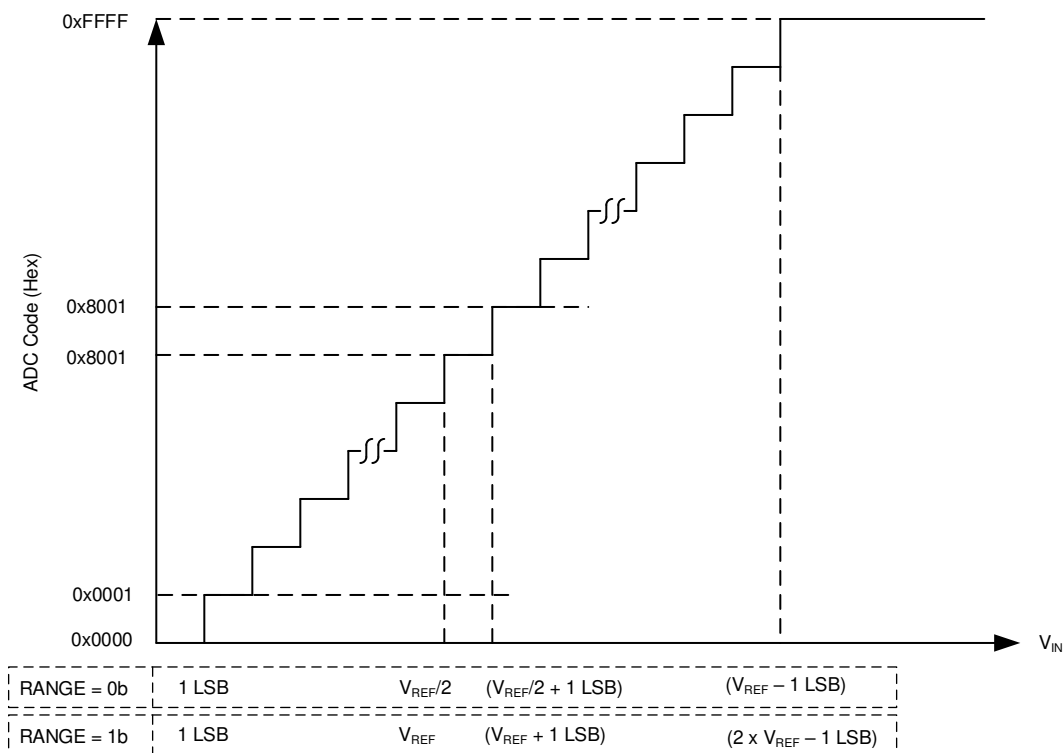

**Figure 7-2. Ideal Transfer Characteristics**

**Table 7-1. Transfer Characteristics**

INPUT VOLTAGE		CODE	IDEAL OUTPUT CODE
RANGE = 0b	RANGE = 1b		
$\leq 1 \text{ LSB}$	$\leq 1 \text{ LSB}$	Zero	0000
1 LSB to 2 LSBs	1 LSB to 2 LSBs	Zero + 1	0001
$(V_{REF} / 2)$ to $(V_{REF} / 2) + 1 \text{ LSB}$	$V_{REF}$ to $V_{REF} + 1 \text{ LSB}$	Mid-scale code	8000
$(V_{REF} / 2) + 1 \text{ LSB}$ to $(V_{REF} / 2) + 2 \text{ LSBs}$	$V_{REF} + 1 \text{ LSB}$ to $V_{REF} + 2 \text{ LSBs}$	Mid-scale code + 1	8001
$\geq V_{REF} - 1 \text{ LSB}$	$\geq 2 \times V_{REF} - 1 \text{ LSB}$	Full-scale code	FFFF

### 7.3.4 ADC Offset Calibration

The variation in ADC offset error resulting from changes in temperature or reference voltage can be calibrated by setting the CAL bit in the GENERAL\_CFG register. The CAL bit is reset to 0 after calibration. The host can poll the CAL bit to check the ADC offset calibration completion status.

### 7.3.5 Programmable Averaging Filters

The ADS7066 features a programmable averaging filter that can be used to average analog input samples to output a higher resolution measurement. The averaging filter can be enabled by programming the OSR[2:0] bits in the OSR\_CFG register to the averaging factor desired. The averaging configuration is common to all analog input channels. As shown in Figure 7-3, the output of the averaging filter is 20 bits long. In manual mode and auto-sequence mode of conversion, only the first conversion for the selected analog input channel must be initiated by the host, as shown in Figure 7-3; any remaining conversions are generated internally. The time ( $t_{AVG}$ ) required to complete the averaging operation is determined by the sampling speed and number of samples to be averaged; see the [Oscillator and Timing Control](#) section for more details. After completion, the averaged 20-bit result, as shown in Figure 7-3, can be read-out. For information on the programmable averaging filters and performance results see the [Resolution-Boosting ADS7066 Using Programmable Averaging Filter application report](#)

In autonomous mode of operation, samples from analog input channels that are enabled in the AUTO\_SEQ\_CH\_SEL register are averaged sequentially.

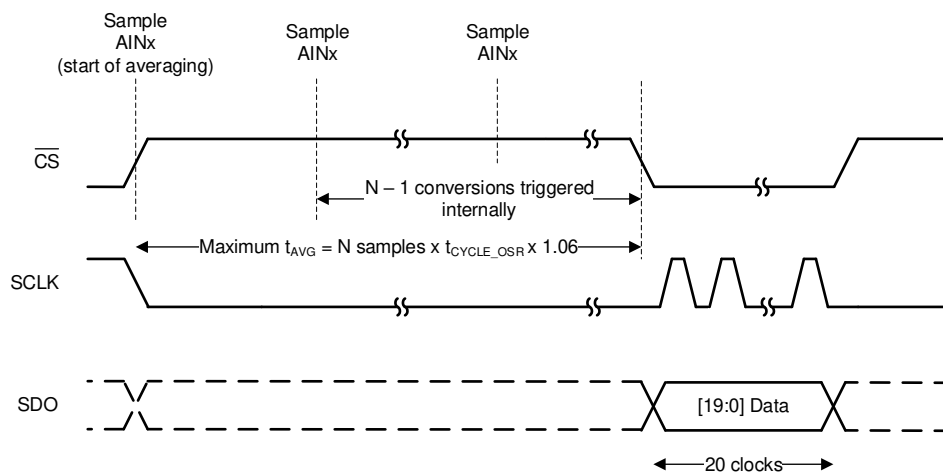

Figure 7-3. Averaged Output Data

### 7.3.6 CRC on Data Interface

The cyclic redundancy check (CRC) is an error checking code that detects communication errors to and from the host. CRC is the division remainder of the data payload bytes by a fixed polynomial. The data payload is two or three bytes, depending on the output data format; see the [Output Data Format](#) section for details on output data format. The CRC mode is optional and is enabled by the CRC\_EN bit in the GENERAL\_CFG register.

The CRC data byte is the 8-bit remainder of the bitwise exclusive-OR (XOR) operation of the argument by a CRC polynomial. The CRC polynomial is based on the CRC-8-CCITT:  $X^8 + X^2 + X^1 + 1$ . The nine binary polynomial coefficients are: 10000111. The CRC calculation is preset with 1 data values. For more details about the CRC implementation and for a software example, see the [Implementation of CRC for ADS7066 application report](#).

The host must compute and append the appropriate CRC to the command string in the same SPI frame (see the [Register Read/Write Operation](#) section). The ADC also computes the expected CRC corresponding to the payload received from the host and compares the calculated CRC code to the CRC received from the host. The CRC received from the host and the CRC calculated by the ADC over the received payload are compared to check for an exact match.

- If the calculated CRC and received CRC match then the data payload received from the host is valid.
- If the calculated CRC and received CRC do not match then the data payload received from the host is not valid and the command does not execute. The CRCERR\_IN flag is set to 1b. ADC conversion data read and register read processes, with a valid CRC from the host, are still supported. The error condition can be detected, as listed in [Table 7-2](#), by either status flags or by a register read. Further register writes to the device are blocked until the CRCERR\_IN flag is cleared to 0b. Register write operations, with a valid CRC from the host, to the SYSTEM\_STATUS (address = 0x00) and GENERAL\_CFG (address = 0x01) registers are still supported.

**Table 7-2. Configuring Notifications When a CRC Error is Detected**

CRC ERROR NOTIFICATION	CONFIGURATION	DESCRIPTION
Status flags	APPEND_STATUS = 10b	4-bit status flags, containing the CRCERR_IN bit appended to the ADC data; see the <a href="#">Output Data Format</a> section for details.
Register read	—	Read the CRCERR_IN bit to check if a CRC error was detected.

For a conversion data read or register data read, the ADC responds with a CRC that is computed over the requested data payload bytes. The response data payload is one, two, or three bytes depending on the data operation (see the [Output CRC \(Device to Host\)](#) section).

### 7.3.7 Oscillator and Timing Control

The device uses an internal oscillator for conversion. When using the averaging module, the host initiates the first conversion and subsequent conversions are generated internally by the device. When the device generates the start of a conversion, the sampling rate can be controlled as described in [Table 7-3](#) by the OSC\_SEL and CLK\_DIV[3:0] register fields.

The conversion time of the device, given by  $t_{CONV}$  in the *Switching Characteristics* table in the [Specifications](#) section, is independent of the OSC\_SEL and CLK\_DIV[3:0] configuration.

**Table 7-3. Configuring the Sampling Rate for Internal Conversion Start Control**

CLK_DIV[3:0]	OSC_SEL = 0		OSC_SEL = 1	
	SAMPLING FREQUENCY, $f_{CYCLE\_OSR}$ (kSPS)	CYCLE TIME, $t_{CYCLE\_OSR}$ ( $\mu$ S)	SAMPLING FREQUENCY, $f_{CYCLE\_OSR}$ (kSPS)	CYCLE TIME, $t_{CYCLE\_OSR}$ ( $\mu$ S)
0000b	Reserved. Do not use.	Reserved. Do not use.	31.25	32
0001b	Reserved. Do not use.	Reserved. Do not use.	20.83	48
0010b	Reserved. Do not use.	Reserved. Do not use.	15.63	64
0011b	Reserved. Do not use.	Reserved. Do not use.	10.42	96
0100b	250	4	7.81	128
0101b	166.7	6	5.21	192
0110b	125	8	3.91	256
0111b	83	12	2.60	384
1000b	62.5	16	1.95	512
1001b	41.7	24	1.3	768
1010b	31.3	32	0.98	1024
1011b	20.8	48	0.65	1536
1100b	15.6	64	0.49	2048
1101b	10.4	96	0.33	3072

### 7.3.8 Diagnostic Modes

The ADS7066 features a programmable test voltage generation circuit that can be used for ADC diagnostics.

#### 7.3.8.1 Bit-Walk Test Mode

To enable write access to the configuration registers for diagnostics, write 0x96 in the DIAGNOSTICS\_KEY register. To enable bit-walk test mode, configure BITWALK\_EN = 1b. In the bit-walk test mode (see [Figure 7-1](#)), the sampling switch (SW) remains open and the test voltage is applied on the sampling capacitor (C<sub>SH</sub>) during the acquisition phase of the ADC. In diagnostic mode, the conversion process of the ADC remains the same as normal device operation. The ADC starts the conversion phase on the rising edge of  $\overline{CS}$  and outputs the code corresponding to the sampled test voltage. The output code of the ADC is expected to be proportional to the test voltage, as shown in [Equation 2](#), after adjusting for DC errors (such as INL, gain error, offset error, and thermal drift of offset and gain errors).

$$\text{Output code} = \left( \frac{\text{Test voltage}}{V_{\text{REF}}} \times 2^{16} \right) \pm \text{TUE} \quad (2)$$

where

- TUE = Total unadjusted error, given by the root sum square of the offset error, gain error, and INL

The test voltage is generated by a DAC configured by the BIT\_SAMPLE\_MSB and BIT\_SAMPLE\_LSB registers. Because the test voltage is derived from the ADC reference, as given by [Equation 3](#), this diagnostic mode is not sensitive to variations in reference voltage.

$$\text{Test voltage} = \frac{V_{\text{REF}}}{\text{BIT\_SAMPLE}[15:0]} \pm \text{TUE} \quad (3)$$

To resume conversion of the ADC input signal, configure BITWALK\_EN = 0b.

#### 7.3.8.2 Fixed Voltage Test Mode

For diagnostics, the ADS7066 features a fixed 1.8 V (typical) test voltage which can be internally connected to AIN6. To connect AIN6 to the internal test voltage, set VTEST\_EN = 1b. When using the fixed voltage test mode, AIN6 pin must be left floating and should not be connected to any external circuit.

If bit-walk test mode is enabled (that is, BITWALK\_EN = 1b), enabling the fixed voltage test mode will connect AIN6 to the test voltage but the conversion result would be according to bit-walk test mode configuration.

### 7.3.9 Output Data Format

[Figure 7-4](#) illustrates that the output data payload consists of a combination of the conversion result, data bits from averaging filters, status flags, and channel ID. The conversion result is MSB aligned. If averaging is enabled, the output data from the ADC are 20 bits long, otherwise the data are 16 bits long. Optionally, the 4-bit channel ID or status flags can be appended at the end of the output data by configuring the APPEND\_STATUS[1:0] fields.

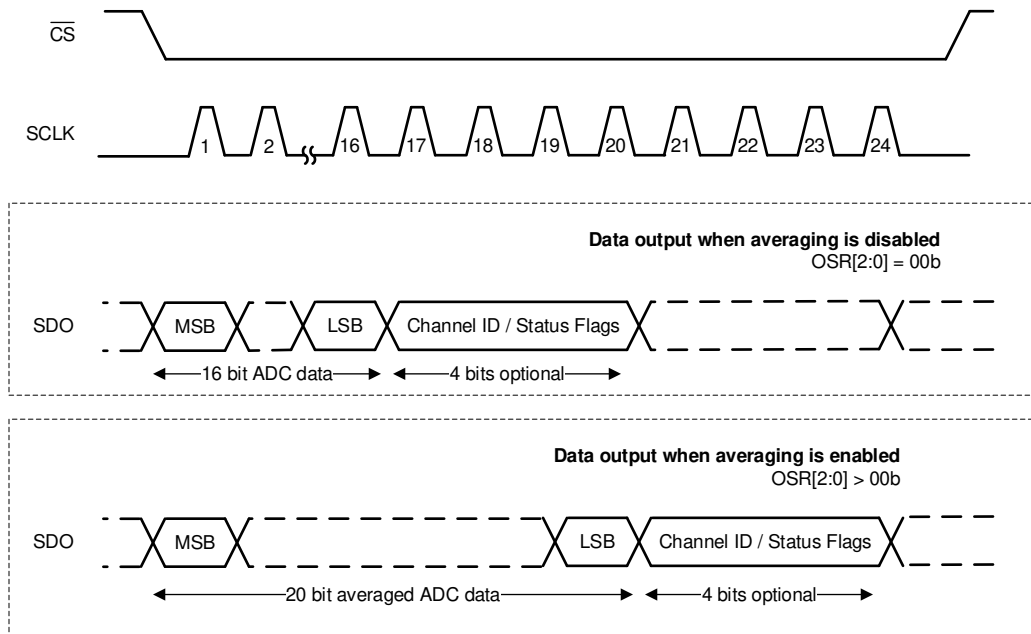

**Figure 7-4. SPI Frames for Reading Data**

### 7.3.9.1 Status Flags

Status flags can be appended to the ADC output by setting `APPEND_STATUS = 10b`. The status flag is appended only to frames where ADC data are being read. Status flags are not appended to data corresponding to a register read operation or when `FIX_PAT = 1b`. The 4-bit status flag field is constructed as follows:

Status flag[3:0] = { 1, VTEST\_MODE, CRCERR\_IN, DIAG\_MODE }

where:

- **VTEST\_MODE**: This flag is set if the current data frame corresponds to fixed voltage test mode (see the [Fixed Voltage Test Mode](#) section).
- **CRCERR\_IN**: This flag indicates the status of the CRC verification of data received from the digital interface. This flag is the same as the `CRCERR_IN` bit in the `SYSTEM_STATUS` register.
- **DIAG\_MODE**: This flag is set if the current data frame corresponds to the bit-walk test mode (see the [Bit-Walk Test Mode](#) section).

### 7.3.9.2 Output CRC (Device to Host)

A CRC byte can be appended to the output data by configuring `CRC_EN` to 1b. When the CRC module is enabled, the host must use 32-bit frames for SPI communication. The device outputs the data payload followed by the CRC byte computed over the data payload. Additional 0s can be appended by the ADC after the CRC byte to complete the 32-bit SPI frame (see [Table 7-4](#)). The host must compute and compare the CRC corresponding to the data payload with the CRC received from the ADC. The additional 0s appended by the device after the CRC byte must be excluded by the host for computing the CRC.

### 7.3.9.3 Input CRC (Host to Device)

When the CRC module is enabled, the host must always communicate with the ADC using 32-bit SPI frames comprised of a 24-bit data payload and an 8-bit CRC byte. The host must calculate the CRC byte to be appended based on a 24-bit payload. The ADC computes a CRC over the 24-bit data payload and compares the result with the CRC received from the host. [Table 7-4](#) lists the output data frames for the `CRC_EN` bit.

**Table 7-4. Output Data Frames**

CRC_EN	OSR[2:0]	APPEND_STATUS[1:0]	OUTPUT DATA FRAME	DAISY-CHAIN MODE
CRC module disabled (CRC_EN = 0)	No averaging	No flags (00b or 11b)	{Conversion result [15:0], 8'b0}	Supported
		Channel ID (01b)	{Conversion result [15:0], CHID[3:0], 4'b0}	Supported
		Status flags (10b)	{Conversion result [15:0], status flags[3:0], 4'b0}	Supported
	Averaging enabled	No flags (00b or 11b)	{Conversion result [19:0], 4'b0}	Supported
		Channel ID (01b)	{Conversion result [19:0], CHID[3:0]}	Supported
		Status flags (10b)	{Conversion result [19:0], status flags[3:0]}	Supported
CRC module enabled (CRC_EN = 1)	No averaging	No flags (00b or 11b)	{Conversion result [15:0], CRC[7:0], 8'b0}	Supported
		Channel ID (01b)	{Conversion result [15:0], CHID[3:0], 4'b0, CRC[7:0]}	Not supported
		Status flags (10b)	{Conversion result [15:0], status flags[3:0], 4'b0, CRC[7:0]}	Not supported
	Averaging enabled	No flags (00b or 11b)	{Conversion result [19:0], 4'b0, CRC[7:0]}	Not supported
		Channel ID (01b)	{Conversion result [19:0], CHID[3:0], CRC[7:0]}	Not supported
		Status flags (10b)	{Conversion result [19:0], status flags[3:0], CRC[7:0]}	Not supported

### 7.3.10 Device Programming

#### 7.3.10.1 Enhanced-SPI Interface

The device features an enhanced-SPI interface that allows the host controller to operate at slower SCLK speeds and still achieve full throughput. As described in [Table 7-5](#), the host controller can use any of the four SPI-compatible protocols (SPI-00, SPI-01, SPI-10, or SPI-11) to access the device.

**Table 7-5. SPI Protocols for Configuring the Device**

PROTOCOL	SCLK POLARITY (At the $\overline{CS}$ Falling Edge)	SCLK PHASE (Capture Edge)	CPOL_CPHA[1:0]	DIAGRAM
SPI-00	Low	Rising	00b	<a href="#">Figure 7-5</a>
SPI-01	Low	Falling	01b	<a href="#">Figure 7-6</a>
SPI-10	High	Falling	10b	<a href="#">Figure 7-5</a>
SPI-11	High	Rising	11b	<a href="#">Figure 7-6</a>

On power-up, the device defaults to the SPI-00 protocol for data read and data write operations. To select a different SPI-compatible protocol, program the CPOL\_CPHA[1:0] field. This first write operation must adhere to the SPI-00 protocol. Any subsequent data transfer frames must adhere to the newly-selected protocol.

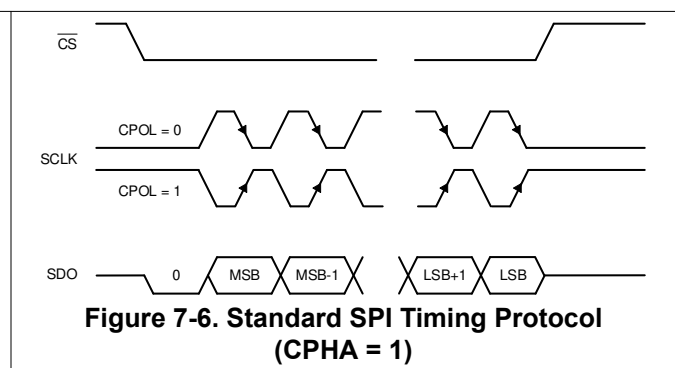
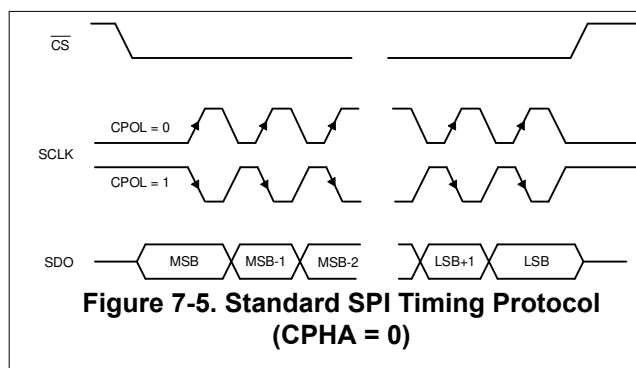

### 7.3.10.2 Daisy-Chain Mode

The ADS7066 can operate as a single converter or in a system with multiple converters. System designers can take advantage of the simple, high-speed, enhanced-SPI serial interface by cascading converters in a daisy-chain configuration when multiple converters are used. No register configuration is required to enable daisy-chain mode. Figure 7-7 shows a typical connection of three converters in daisy-chain mode.

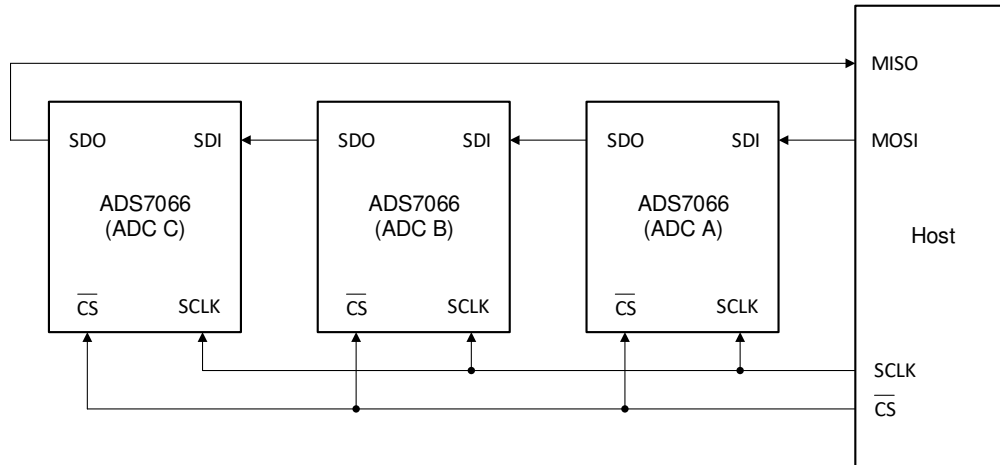

**Figure 7-7. Multiple Converters Connected Using Daisy-Chain Mode**

When the ADS7066 is connected in daisy-chain mode, the serial input data passes through the ADS7066 with a 24-SCLK delay, as long as  $\overline{CS}$  is active. Figure 7-8 shows a detailed timing diagram of this mode. In Figure 7-8, the conversion in each converter is performed simultaneously.

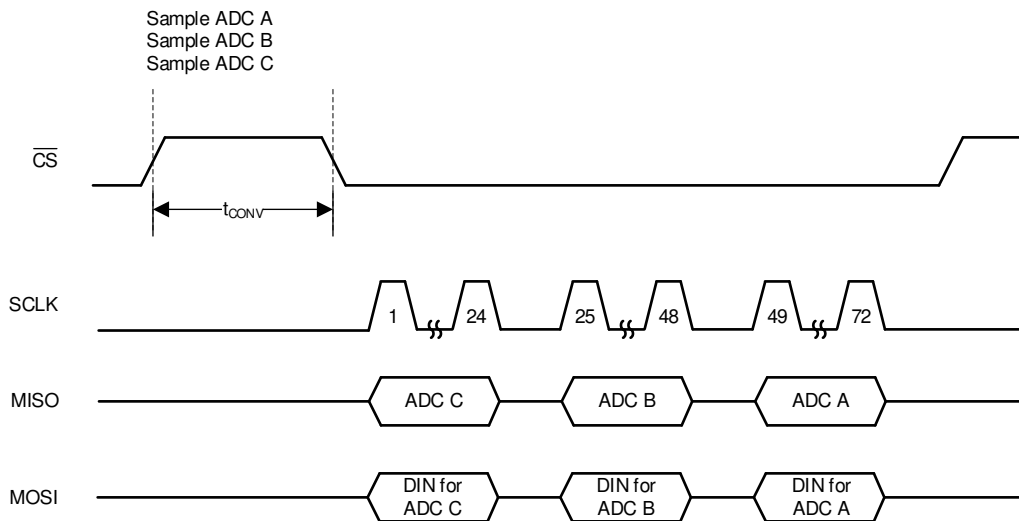

**Figure 7-8. Simplified Daisy-Chain Mode Timing**

The ADS7066 supports daisy-chain mode for output data payloads up to 24 bits long; see the [Output Data Format](#) section for more details. If either the status flags or channel ID are appended (APPEND\_STATUS ≠ 00b) and the CRC module is enabled (CRC\_EN = 1b), then the serial input data does not pass through the ADS7066 and daisy-chain mode is disabled.

### 7.3.10.3 Register Read/Write Operation

The device supports the commands listed in [Table 7-6](#) to access the internal configuration registers

**Table 7-6. Opcodes for Commands**

OPCODE	COMMAND DESCRIPTION
0000 0000b	No operation
0001 0000b	Single register read
0000 1000b	Single register write
0001 1000b	Set bit
0010 0000b	Clear bit

#### 7.3.10.3.1 Register Write

A 24-bit SPI frame is required to write data to configuration registers. The 24-bit data on SDI, as shown in [Figure 7-9](#), consists of an 8-bit write command (0000 1000b), an 8-bit register address, and 8-bit data. The write command is decoded on the  $\overline{CS}$  rising edge and the specified register is updated with the 8-bit data specified in the register write operation.

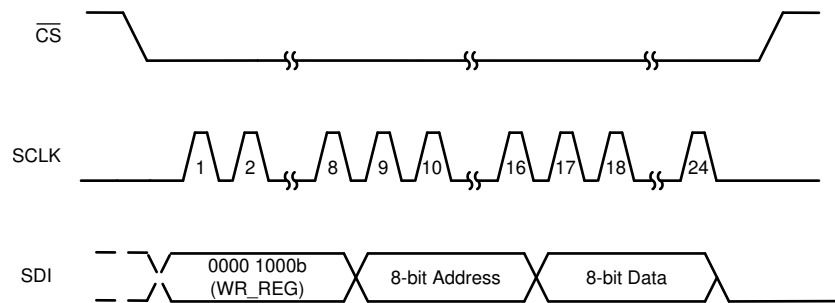

**Figure 7-9. Register Write Operation**

#### 7.3.10.3.2 Register Read

A register read operation consists of two SPI frames: the first SPI frame initiates a register read and the second SPI frame reads data from the register address provided in the first frame. As shown in [Figure 7-10](#), the read command (0001 0000b), the 8-bit register address, and the 8-bit dummy data are sent over the SDI pin during the first 24-bit frame. On the rising edge of  $\overline{CS}$ , the read command is decoded and the requested register data are available for reading during the next frame. During the second frame, the first eight bits on SDO correspond to the requested register read. During the second frame, SDI can be used to initiate another operation or can be set to 0.

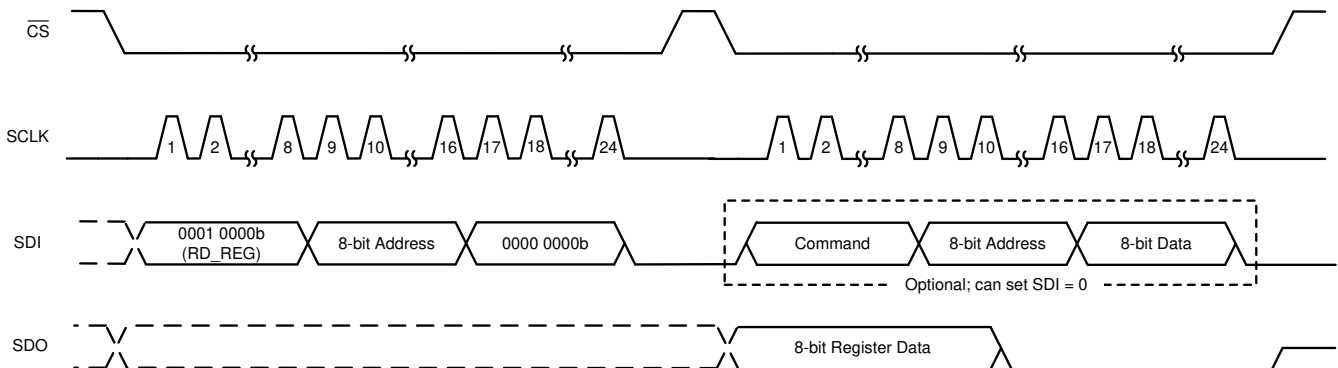

**Figure 7-10. Register Read Operation**

**7.3.10.3.2.1 Register Read With CRC**

A register read consists of two SPI frames, as described in the *Register Read* section. When the CRC module is enabled during a register read, as shown in *Figure 7-11*, the device appends an 8-bit output CRC byte along with 8-bit register data. The output CRC is computed by the device on the 8-bit register data.

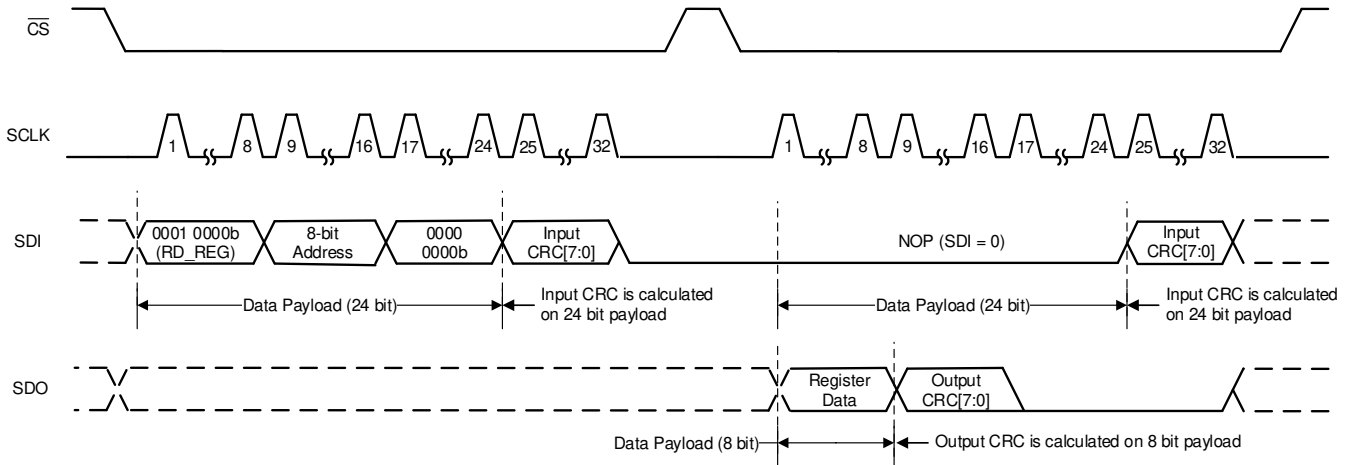

**Figure 7-11. Register Read With CRC**

## 7.4 Device Functional Modes

Table 7-7 lists the functional modes supported by the ADS7066.

**Table 7-7. Functional Modes**

FUNCTIONAL MODE	CONVERSION CONTROL	MUX CONTROL	SEQ_MODE[1:0]
Manual	$\overline{CS}$ rising edge	Register write to MANUAL_CHID	00b
On-the-fly	$\overline{CS}$ rising edge	First 5 bits after $\overline{CS}$ falling edge	10b
Auto-sequence	$\overline{CS}$ rising edge	Channel sequencer	01b
Autonomous	Internal to the device	Channel sequencer	01b

The device powers up in manual mode and can be configured into either of these modes by writing the configuration registers for the desired mode.

### 7.4.1 Device Power-Up and Reset

On power up, the BOR bit is set indicating a power-cycle or reset event. The device can be reset by setting the RST bit or by recycling the power on the AVDD pin.

### 7.4.2 Manual Mode

Manual mode allows the external host processor to directly select the analog input channel. Figure 7-12 shows steps for operating the device in manual mode.

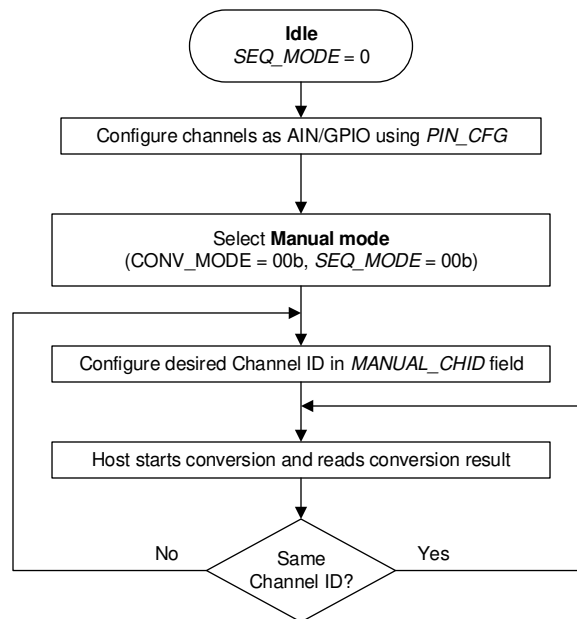

**Figure 7-12. Device Operation in Manual Mode**

In manual mode, the command to switch to a new channel, cycle N in Figure 7-13, is decoded by the device on the  $\overline{CS}$  rising edge. The  $\overline{CS}$  rising edge is also the start of the conversion cycle, and thus the device samples the previously selected MUX channel in cycle N+1. The newly selected analog input channel data are available in cycle N+2. For switching the analog input channel, a register write to the MANUAL\_CHID field requires 24 clocks; see the Register Write section for more details. After a channel is selected, the number of clocks required for reading the output data depends on the device output data frame size; see the Output Data Format section for more details.

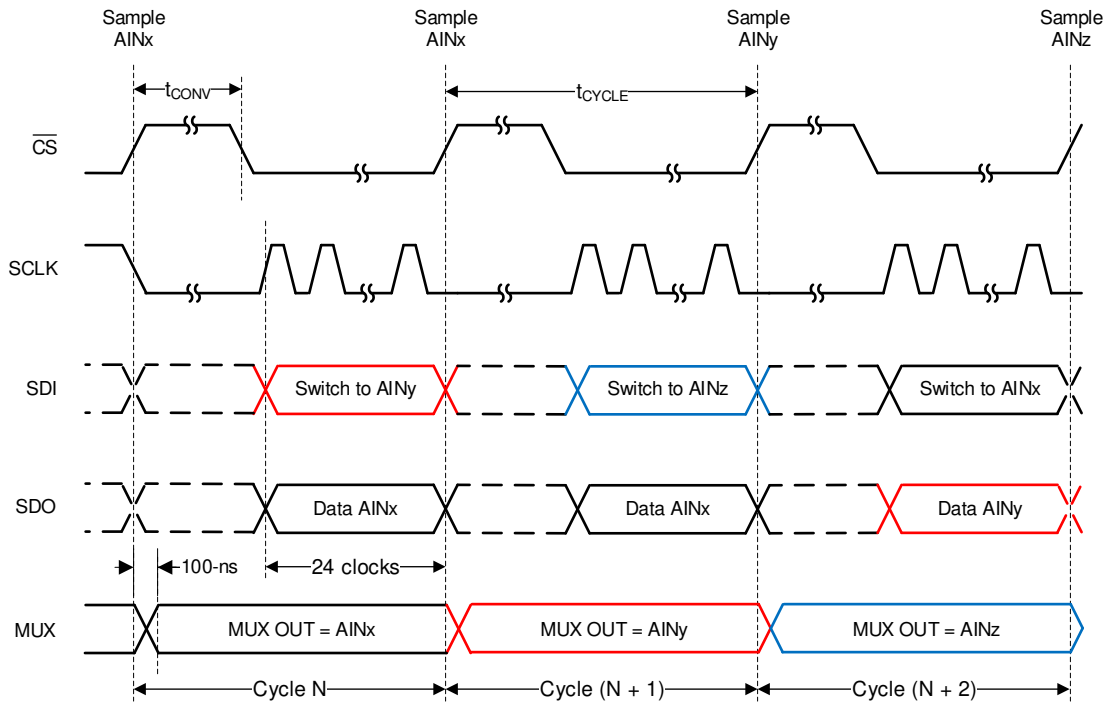

**Figure 7-13. Starting a Conversion and Reading Data in Manual Mode**

### 7.4.3 On-the-Fly Mode

In the on-the-fly mode of operation, as shown in Figure 7-14, the analog input channel is selected using the first five bits on SDI without waiting for the  $\overline{CS}$  rising edge. Thus, the ADC samples the newly selected channel on the  $\overline{CS}$  rising edge and there is no latency between the channel selection and the ADC output data. Table 7-8 lists the channel selection commands for this mode.

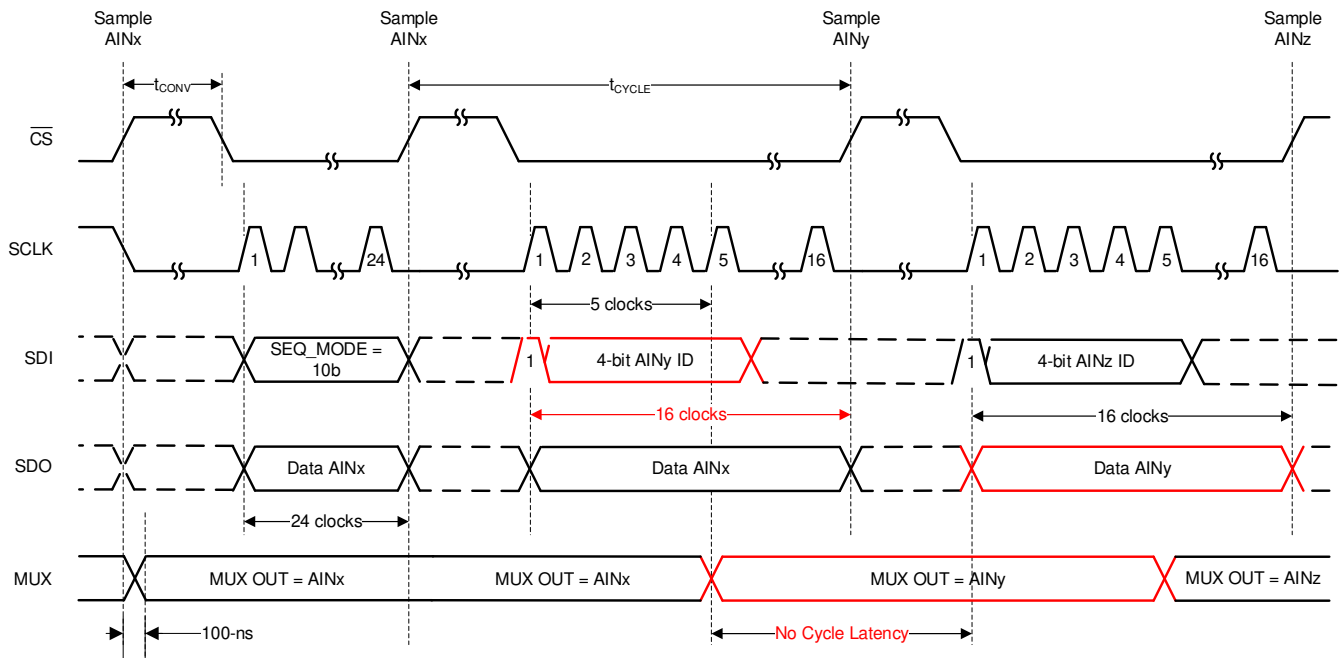

**Figure 7-14. Starting a Conversion and Reading data in On-the-Fly Mode**

**Table 7-8. On-the-Fly Mode Channel Selection Commands**

SDI BITS[15:11]	SDI BITS [10:0]	DESCRIPTION
1 0000	Don't care	Select analog input 0
1 0001	Don't care	Select analog input 1
1 0010	Don't care	Select analog input 2
1 0011	Don't care	Select analog input 3
1 0100	Don't care	Select analog input 4
1 0101	Don't care	Select analog input 5
1 0110	Don't care	Select analog input 6
1 0111	Don't care	Select analog input 7
1 1000 to 1 1111	Don't care	Reserved

The number of clocks required for reading the output data depends on the device output data frame size; see the [Output Data Format](#) section for more details.

### 7.4.4 Auto-Sequence Mode

In auto-sequence mode, the internal channel sequencer switches the multiplexer to the next analog input channel after every conversion. The desired analog input channels can be configured for sequencing in the AUTO\_SEQ\_CHSEL register. To enable the channel sequencer, set SEQ\_START = 1b. After every conversion, the channel sequencer switches the multiplexer to the next analog input in ascending order. To stop the channel sequencer from selecting channels, set SEQ\_START = 0b.

In the example shown in [Figure 7-15](#), AIN2 and AIN6 are enabled for sequencing in the AUTO\_SEQ\_CHSEL register. The channel sequencer loops through AIN2 and AIN6 and repeats until SEQ\_START is set to 0b. The number of clocks required for reading the output data depends on the device output data frame size; see the [Output Data Format](#) section for more details.

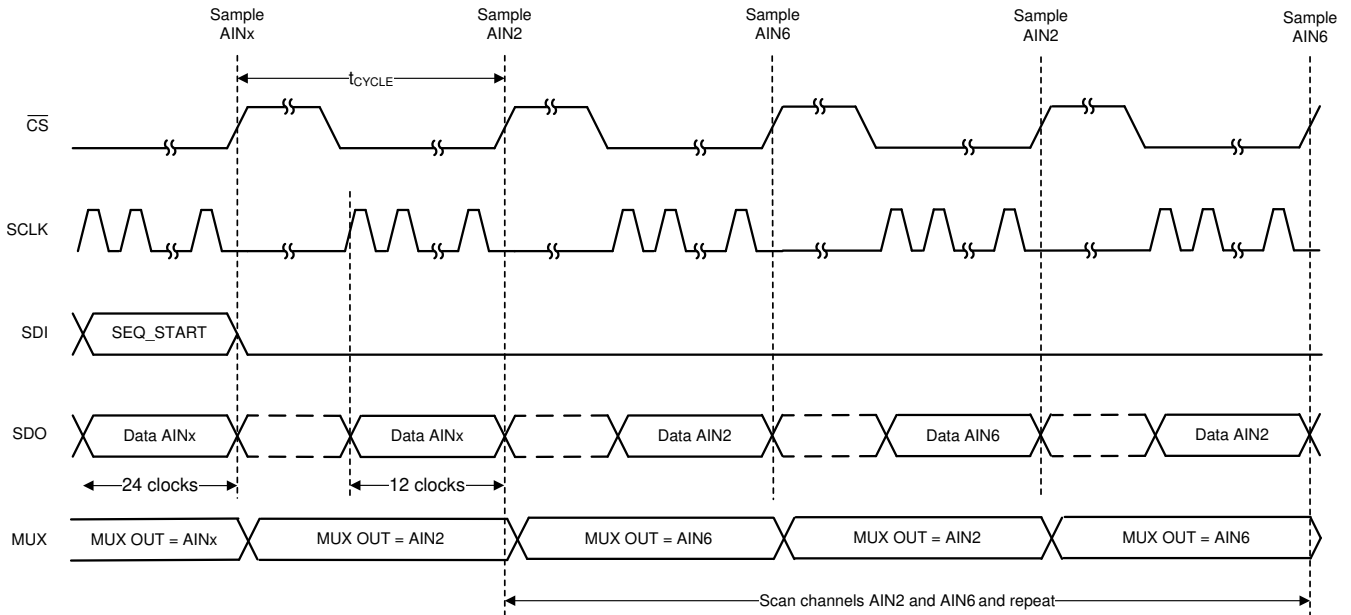

**Figure 7-15. Starting Conversion and Reading Data in Auto-Sequence Mode**

## 7.5 ADS7066 Registers

[ADS7066 Registers](#) lists the memory-mapped registers for the ADS7066 registers. All register offset addresses not listed in [ADS7066 Registers](#) should be considered as reserved locations and the register contents should not be modified.

**Table 7-9. ADS7066 Registers**

Address	Acronym	Register Name	Section
0x0	SYSTEM_STATUS		<a href="#">Section 7.5.1</a>
0x1	GENERAL_CFG		<a href="#">Section 7.5.2</a>
0x2	DATA_CFG		<a href="#">Section 7.5.3</a>
0x3	OSR_CFG		<a href="#">Section 7.5.4</a>
0x4	OPMODE_CFG		<a href="#">Section 7.5.5</a>
0x5	PIN_CFG		<a href="#">Section 7.5.6</a>
0x7	GPIO_CFG		<a href="#">Section 7.5.7</a>
0x9	GPO_DRIVE_CFG		<a href="#">Section 7.5.8</a>
0xB	GPO_OUTPUT_VALUE		<a href="#">Section 7.5.9</a>
0xD	GPI_VALUE		<a href="#">Section 7.5.10</a>
0x10	SEQUENCE_CFG		<a href="#">Section 7.5.11</a>
0x11	CHANNEL_SEL		<a href="#">Section 7.5.12</a>
0x12	AUTO_SEQ_CH_SEL		<a href="#">Section 7.5.13</a>
0xBF	DIAGNOSTICS_KEY		<a href="#">Section 7.5.14</a>
0xC0	DIAGNOSTICS_EN		<a href="#">Section 7.5.15</a>
0xC1	BIT_SAMPLE_LSB		<a href="#">Section 7.5.16</a>
0xC2	BIT_SAMPLE_MSB		<a href="#">Section 7.5.17</a>

Complex bit access types are encoded to fit into small table cells. [ADS7066 Access Type Codes](#) shows the codes that are used for access types in this section.

**Table 7-10. ADS7066 Access Type Codes**

Access Type	Code	Description
<b>Read Type</b>		
R	R	Read
<b>Write Type</b>		
W	W	Write
<b>Reset or Default Value</b>		
-n		Value after reset or the default value
<b>Register Array Variables</b>		
i,j,k,l,m,n		When these variables are used in a register name, an offset, or an address, they refer to the value of a register array where the register is part of a group of repeating registers. The register groups form a hierarchical structure and the array is represented with a formula.
y		When this variable is used in a register name, an offset, or an address it refers to the value of a register array.

### 7.5.1 SYSTEM\_STATUS Register (Address = 0x0) [Reset = 0x81]

SYSTEM\_STATUS is shown in [SYSTEM\\_STATUS Register Field Descriptions](#).

Return to the [ADS7066 Registers](#).

**Table 7-11. SYSTEM\_STATUS Register Field Descriptions**

Bit	Field	Type	Reset	Description
7	RSVD	R	1b	Reads return 1b.
6	SEQ_STATUS	R	0b	Status of the channel sequencer. 0b = Sequence stopped 1b = Sequence in progress
5-3	RESERVED	R	000b	Reserved Bit
2	CRCERR_FUSE	R	0b	Device power-up configuration CRC check status. To re-evaluate this bit, software reset the device or power cycle AVDD. 0b = No problems detected in power-up configuration. 1b = Device configuration not loaded correctly.
1	CRCERR_IN	R/W	0b	Status of CRC check on incoming data. Write 1b to clear this error flag. 0b = No CRC error. 1b = CRC error detected. All register writes, except to addresses 0x00 and 0x01, are blocked.
0	BOR	R/W	1b	Brown out reset indicator. This bit is set if brown out condition occurs or device is power cycled. Write 1b to this bit to clear the flag. 0b = No brown out since last time this bit was cleared. 1b = Brown out condition detected or device power cycled.

### 7.5.2 GENERAL\_CFG Register (Address = 0x1) [Reset = 0x00]

GENERAL\_CFG is shown in [GENERAL\\_CFG Register Field Descriptions](#).

Return to the [ADS7066 Registers](#).

**Table 7-12. GENERAL\_CFG Register Field Descriptions**

Bit	Field	Type	Reset	Description
7	REF_EN	R/W	0b	Enable or disable the internal reference. 0b = Internal reference is powered down. 1b = Internal reference is enabled.
6	CRC_EN	R/W	0b	Enable or disable the CRC on device interface. 0b = CRC module disabled. 1b = CRC appended to data output. CRC check is enabled on incoming data.
5-4	RESERVED	R	00b	Reserved Bit
3	RANGE	R/W	0b	Select the input range of the ADC. 0b = Input range of the ADC is 1x VREF 1b = Input range of the ADC is 2x VREF
2	CH_RST	R/W	0b	Force all channels to be analog inputs. 0b = Normal operation 1b = All channels will be set as analog inputs irrespective of configuration in other registers
1	CAL	R/W	0b	Calibrate ADC offset. 0b = Normal operation. 1b = ADC offset is calibrated. After calibration is complete, this bit is set to 0b.

**Table 7-12. GENERAL\_CFG Register Field Descriptions (continued)**

Bit	Field	Type	Reset	Description
0	RST	W	0b	Software reset all registers to default values. 0b = Normal operation. 1b = Device is reset. After reset is complete, this bit is set to 0b and BOR bit is set to 1b.

**7.5.3 DATA\_CFG Register (Address = 0x2) [Reset = 0x00]**

DATA\_CFG is shown in [DATA\\_CFG Register Field Descriptions](#).

Return to the [ADS7066 Registers](#).

**Table 7-13. DATA\_CFG Register Field Descriptions**

Bit	Field	Type	Reset	Description
7	FIX_PAT	R/W	0b	Device outputs fixed data bits which can be helpful for debugging communication with the device. 0b = Normal operation. 1b = Device outputs fixed code 0xA5A5 repeatedly when reading ADC data.
6	RESERVED	R	0b	Reserved Bit
5-4	APPEND_STATUS[1:0]	R/W	00b	Append 4-bit channel ID or status flags to output data. 00b = Channel ID and status flags are not appended to ADC data. 01b = 4-bit channel ID is appended to ADC data. 10b = 4-bit status flags are appended to ADC data. 11b = Reserved.
3-2	RESERVED	R	00b	Reserved Bit
1-0	CPOL_CPHA[1:0]	R/W	00b	This field sets the polarity and phase of SPI communication. 00b = CPOL = 0, CPHA = 0. 01b = CPOL = 0, CPHA = 1. 10b = CPOL = 1, CPHA = 0. 11b = CPOL = 1, CPHA = 1.

**7.5.4 OSR\_CFG Register (Address = 0x3) [Reset = 0x00]**

OSR\_CFG is shown in [OSR\\_CFG Register Field Descriptions](#).

Return to the [ADS7066 Registers](#).

**Table 7-14. OSR\_CFG Register Field Descriptions**

Bit	Field	Type	Reset	Description
7-3	RESERVED	R	00000b	Reserved Bit
2-0	OSR[2:0]	R/W	000b	Selects the oversampling ratio for ADC conversion result. 000b = No averaging 001b = 2 samples 010b = 4 samples 011b = 8 samples 100b = 16 samples 101b = 32 samples 110b = 64 samples 111b = 128 samples

### 7.5.5 OPMODE\_CFG Register (Address = 0x4) [Reset = 0x04]

OPMODE\_CFG is shown in [OPMODE\\_CFG Register Field Descriptions](#).

Return to the [ADS7066 Registers](#).

**Table 7-15. OPMODE\_CFG Register Field Descriptions**

Bit	Field	Type	Reset	Description
7-5	RESERVED	R	000b	Reserved Bit
4	OSC_SEL	R/W	0b	Selects the oscillator for internal timing generation. 0b = High-speed oscillator. 1b = Low-power oscillator.
3-0	CLK_DIV[3:0]	R/W	0100b	Sampling speed control when using averaging filters. Refer to section on oscillator and timing control for details.

### 7.5.6 PIN\_CFG Register (Address = 0x5) [Reset = 0x00]

PIN\_CFG is shown in [PIN\\_CFG Register Field Descriptions](#).

Return to the [ADS7066 Registers](#).

**Table 7-16. PIN\_CFG Register Field Descriptions**

Bit	Field	Type	Reset	Description
7-0	PIN_CFG[7:0]	R/W	00000000b	Configure device channels AIN/GPIO [7:0] as analog inputs or GPIOs. 00000000b = Channel is configured as analog input. 00000001b = Channel is configured as GPIO.

### 7.5.7 GPIO\_CFG Register (Address = 0x7) [Reset = 0x00]

GPIO\_CFG is shown in [GPIO\\_CFG Register Field Descriptions](#).

Return to the [ADS7066 Registers](#).

**Table 7-17. GPIO\_CFG Register Field Descriptions**

Bit	Field	Type	Reset	Description
7-0	GPIO_CFG[7:0]	R/W	00000000b	Configure GPIO[7:0] as either digital inputs or digital outputs. 00000000b = GPIO is configured as digital input. 00000001b = GPIO is configured as digital output.

### 7.5.8 GPO\_DRIVE\_CFG Register (Address = 0x9) [Reset = 0x00]

GPO\_DRIVE\_CFG is shown in [GPO\\_DRIVE\\_CFG Register Field Descriptions](#).

Return to the [ADS7066 Registers](#).

**Table 7-18. GPO\_DRIVE\_CFG Register Field Descriptions**

Bit	Field	Type	Reset	Description
7-0	GPO_DRIVE_CFG[7:0]	R/W	00000000b	Configure digital outputs GPO[7:0] as open-drain or push-pull outputs. 00000000b = Digital output is open-drain; connect external pullup resistor. 00000001b = Push-pull driver is used for digital output.

### 7.5.9 GPO\_OUTPUT\_VALUE Register (Address = 0xB) [Reset = 0x00]

GPO\_OUTPUT\_VALUE is shown in [GPO\\_OUTPUT\\_VALUE Register Field Descriptions](#).

Return to the [ADS7066 Registers](#).

**Table 7-19. GPO\_OUTPUT\_VALUE Register Field Descriptions**

Bit	Field	Type	Reset	Description
7-0	GPO_OUTPUT_VALUE[7:0]	R/W	00000000b	Logic level to be set on digital outputs GPO[7:0]. 00000000b = Digital output set to logic 0. 00000001b = Digital output set to logic 1.

### 7.5.10 GPI\_VALUE Register (Address = 0xD) [Reset = 0x00]

GPI\_VALUE is shown in [GPI\\_VALUE Register Field Descriptions](#).

Return to the [ADS7066 Registers](#).

**Table 7-20. GPI\_VALUE Register Field Descriptions**

Bit	Field	Type	Reset	Description
7-0	GPI_VALUE[7:0]	R	00000000b	Readback the logic level on GPIO[7:0]. 00000000b = GPIO is at logic 0. 00000001b = GPIO is at logic 1.

### 7.5.11 SEQUENCE\_CFG Register (Address = 0x10) [Reset = 0x00]

SEQUENCE\_CFG is shown in [SEQUENCE\\_CFG Register Field Descriptions](#).

Return to the [ADS7066 Registers](#).

**Table 7-21. SEQUENCE\_CFG Register Field Descriptions**

Bit	Field	Type	Reset	Description
7-5	RESERVED	R	000b	Reserved Bit
4	SEQ_START	R/W	0b	Control for start of channel sequence when using auto sequence mode (SEQ_MODE = 01b). 0b = Stop channel sequencing. 1b = Start channel sequencing in ascending order for channels enabled in AUTO_SEQ_CH_SEL register.
3-2	RESERVED	R	00b	Reserved Bit
1-0	SEQ_MODE[1:0]	R/W	00b	Selects the mode of scanning of analog input channels. 00b = Manual sequence mode; channel selected by MANUAL_CHID field. 01b = Auto sequence mode; channel selected by AUTO_SEQ_CHSEL. 10b = On-the-fly sequence mode. 11b = Reserved.

### 7.5.12 CHANNEL\_SEL Register (Address = 0x11) [Reset = 0x00]

CHANNEL\_SEL is shown in [CHANNEL\\_SEL Register Field Descriptions](#).

Return to the [ADS7066 Registers](#).

**Table 7-22. CHANNEL\_SEL Register Field Descriptions**

Bit	Field	Type	Reset	Description
7-4	RESERVED	R	0000b	Reserved Bit

**Table 7-22. CHANNEL\_SEL Register Field Descriptions (continued)**

Bit	Field	Type	Reset	Description
3-0	MANUAL_CHID[3:0]	R/W	0000b	In manual mode (SEQ_MODE = 00b), this field contains the 4-bit channel ID of the analog input channel for next ADC conversion. For valid ADC data, the selected channel must not be configured as GPIO in PIN_CFG register. 1xxx = Reserved. 0000b = AIN0 0001b = AIN1 0010b = AIN2 0011b = AIN3 0100b = AIN4 0101b = AIN5 0110b = AIN6 0111b = AIN7 1000b = Reserved.

### 7.5.13 AUTO\_SEQ\_CH\_SEL Register (Address = 0x12) [Reset = 0x00]

AUTO\_SEQ\_CH\_SEL is shown in [AUTO\\_SEQ\\_CH\\_SEL Register Field Descriptions](#).

Return to the [ADS7066 Registers](#).

**Table 7-23. AUTO\_SEQ\_CH\_SEL Register Field Descriptions**

Bit	Field	Type	Reset	Description
7-0	AUTO_SEQ_CH_SEL[7:0]	R/W	00000000b	Select analog input channels AIN[7:0] in for auto sequencing mode. 00000000b = Analog input channel is not enabled in scanning sequence. 00000001b = Analog input channel is enabled in scanning sequence.

### 7.5.14 DIAGNOSTICS\_KEY Register (Address = 0xBF) [Reset = 0x00]

DIAGNOSTICS\_KEY is shown in [DIAGNOSTICS\\_KEY Register Field Descriptions](#).

Return to the [ADS7066 Registers](#).

**Table 7-24. DIAGNOSTICS\_KEY Register Field Descriptions**

Bit	Field	Type	Reset	Description
7-0	DIAG_KEY[7:0]	R/W	00000000b	Enable write access to diagnostics registers in address locations 0xC0, 0xC1, and 0xC2. Write 0x96 to this register to enable write access to diagnostics registers.

### 7.5.15 DIAGNOSTICS\_EN Register (Address = 0xC0) [Reset = 0x00]

DIAGNOSTICS\_EN is shown in [DIAGNOSTICS\\_EN Register Field Descriptions](#).

Return to the [ADS7066 Registers](#).

**Table 7-25. DIAGNOSTICS\_EN Register Field Descriptions**

Bit	Field	Type	Reset	Description
7-5	RESERVED	R	000b	Reserved Bit

**Table 7-25. DIAGNOSTICS\_EN Register Field Descriptions (continued)**

Bit	Field	Type	Reset	Description
4	VTEST_EN	R/W	0b	Enable measurement of internal 1.8 V (typical) test voltage using AIN6. When using this mode, AIN6 pin should not be left floating and should not be connected to any external circuit. If BITWALK_EN = 1b, this bit has no effect. 0b = Normal operation. 1b = AIN6 is internally connected to 1.8V (typical) test voltage. AIN6 pin should be floating and should not be connected to any external circuit.
3-1	RESERVED	R	000b	Reserved Bit
0	BITWALK_EN	R/W	0b	Enable bit-walk mode of the ADC bit decisions. 0b = Normal operation. 1b = Bit walk mode enabled.

**7.5.16 BIT\_SAMPLE\_LSB Register (Address = 0xC1) [Reset = 0x00]**

BIT\_SAMPLE\_LSB is shown in [BIT\\_SAMPLE\\_LSB Register Field Descriptions](#).

Return to the [ADS7066 Registers](#).

**Table 7-26. BIT\_SAMPLE\_LSB Register Field Descriptions**

Bit	Field	Type	Reset	Description
7-0	BIT_SAMPLE_LSB[7:0]	R/W	00000000b	Define the [7:0] bit positions during sampling phase of the ADC. This field has no effect when DIAG_EN = 0.

**7.5.17 BIT\_SAMPLE\_MSB Register (Address = 0xC2) [Reset = 0x00]**

BIT\_SAMPLE\_MSB is shown in [BIT\\_SAMPLE\\_MSB Register Field Descriptions](#).

Return to the [ADS7066 Registers](#).

**Table 7-27. BIT\_SAMPLE\_MSB Register Field Descriptions**

Bit	Field	Type	Reset	Description
7-0	BIT_SAMPLE_MSB[7:0]	R/W	00000000b	Define the [15:8] bit positions during sampling phase of the ADC. This field has no effect when DIAG_EN = 0.

## 8 Application and Implementation

### Note

Information in the following applications sections is not part of the TI component specification, and TI does not warrant its accuracy or completeness. TI's customers are responsible for determining suitability of components for their purposes, as well as validating and testing their design implementation to confirm system functionality.

### 8.1 Application Information

The primary circuit required to maximize the performance of a high-precision, successive approximation register (SAR), analog-to-digital converter (ADC) is the input driver circuits. This section details some general principles for designing the input driver circuit for the ADS7066.

### 8.2 Typical Application

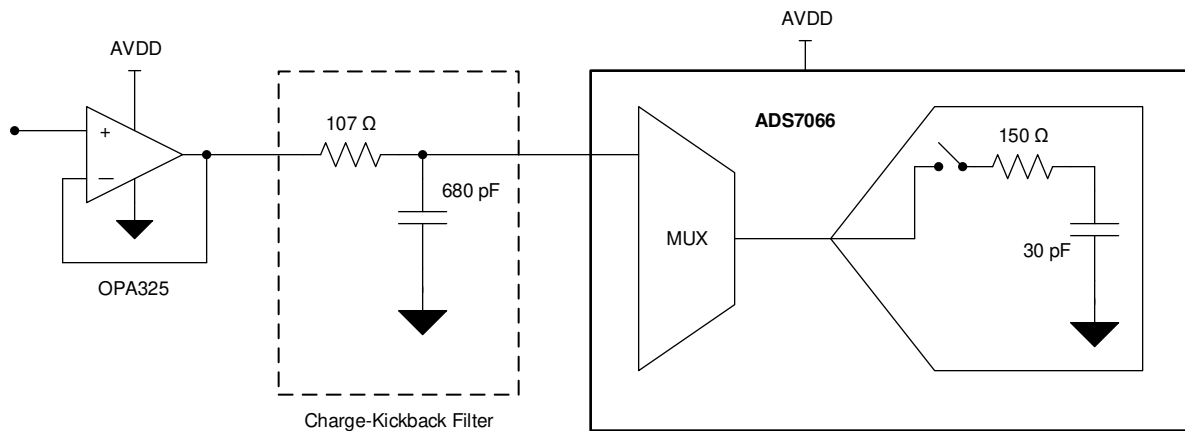

**Figure 8-1. DAQ Circuit: Single-Supply DAQ**

#### 8.2.1 Design Requirements

The goal of this application is to design a single-supply digital acquisition (DAQ) circuit based on the ADS7066 with SNR greater than 80 dB and THD less than  $-80$  dB for input frequencies of 2 kHz at full throughput.

#### 8.2.2 Detailed Design Procedure

The optimal input driver circuit for a high-precision SAR ADC consists of a driving amplifier and a charge-kickback filter (RC filter). The amplifier driving the ADC must have low output impedance and be able to charge the internal sampling capacitor to a 16-bit settling level within the minimum acquisition time. The charge-kickback filter helps attenuate the sampling charge injection from the switched-capacitor input stage of the ADC and helps reduce the wide-band noise contributed by the front-end circuit.

### 8.2.2.1 Charge-Kickback Filter and ADC Amplifier

As illustrated in [Figure 8-1](#), a filter capacitor ( $C_{FLT}$ ) is connected from each input pin of the ADC to ground. This capacitor helps reduce the sampling charge injection and provides a charge bucket to quickly charge the internal sample-and-hold capacitors during the acquisition process. This capacitor must be a COG- or NPO-type. One method for determining the required amplifier bandwidth and the values of the RC charge-kickback filter is provided in this section. This optimization and more details on the math behind the component selection are covered in [ADC Precision Labs](#).

The minimum bandwidth of the amplifier for driving the ADC can be computed using the settling accuracy (0.5 LSB) and settling time (acquisition time) information. [Equation 4](#), [Equation 5](#), [Equation 6](#), and [Equation 7](#) compute the unity-gain bandwidth (UGBW) of the amplifier.

$$LSB = \frac{V_{REF}}{2^N} = \frac{2.5 V}{2^{16}} = 38.2 \mu V \quad (4)$$

$$\tau_c = \frac{-t_{ACQ}}{\ln\left(\frac{0.5 \cdot LSB}{100 mV}\right)} = \frac{-800 ns}{\ln\left(\frac{0.5 \cdot (38.2 \mu V)}{100 mV}\right)} = 93.4 ns \quad (5)$$

$$\tau_{oa} = \frac{\tau_c}{\sqrt{17}} = \frac{93.4 ns}{\sqrt{17}} = 22.7 ns \quad (6)$$

$$UGBW = \frac{1}{2 \cdot \pi \cdot \tau_{oa}} = \frac{1}{2 \cdot \pi \cdot (22.7 ns)} = 7 MHz \quad (7)$$

Based on the result of [Equation 7](#), select an amplifier that has more than 7-MHz UGBW. For this example, [OPA325](#) is used.

The value of  $C_{filt}$  is computed in [Equation 8](#) by taking 20 times the internal sample-and-hold capacitance. The factor of 20 is a rule of thumb that is intended to minimize the droop in voltage on the charge-bucket capacitor,  $C_{filt}$ , after the start of the acquisition period. The filter resistor,  $R_{filt}$ , is computed in [Equation 9](#) using the op-amp time constant and  $C_{filt}$ . [Equation 10](#) and [Equation 11](#) compute the minimum and maximum  $R_{filt}$  values, respectively.

$$C_{filt} = 20 \cdot C_{SH} = 20 \cdot (30 pF) = 600 pF \quad (8)$$

The value of  $C_{filt}$  can be approximated to the nearest standard value 680 pF.

$$R_{filt} = \frac{4 \times \tau_{oa}}{C_{filt}} = \frac{4 \times (22.7 ns)}{680 pF} = 133.5 \Omega \quad (9)$$

$$R_{filt Min} = 0.25 \times R_{filt} = 0.25 \times (133.5 \Omega) = 33.4 \Omega \quad (10)$$

$$R_{filt Max} = 2 \times R_{filt} = 2 \times (133.5 \Omega) = 267 \Omega \quad (11)$$

### 8.2.3 Application Curve

Figure 8-2 shows the FFT plot for the ADS7066 with a 2-kHz input frequency used for the circuit in Figure 8-1.

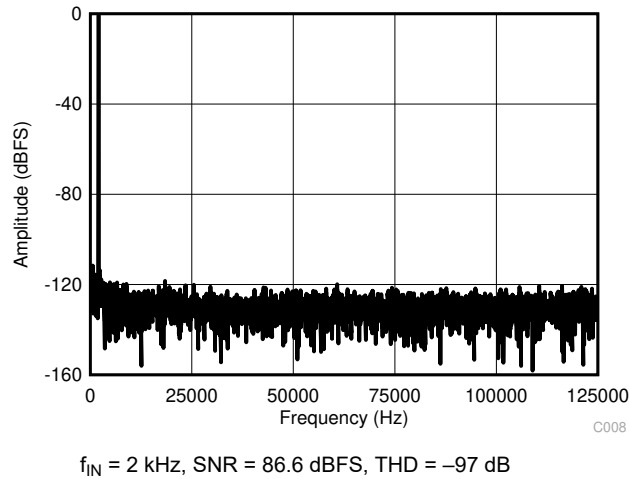
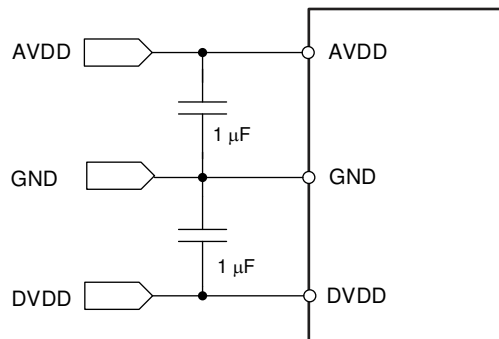

**Figure 8-2. Test Results for the Single-Supply DAQ Circuit**

## 9 Power Supply Recommendations

### 9.1 AVDD and DVDD Supply Recommendations

The ADS7066 has two separate power supplies: AVDD and DVDD. The device operates on AVDD; DVDD is used for the interface circuits. AVDD and DVDD can be independently set to any value within the permissible ranges. As shown in Figure 9-1, decouple the AVDD and DVDD pins individually with 1- $\mu\text{F}$  ceramic decoupling capacitors.



**Figure 9-1. Power-Supply Decoupling**

## 10 Layout

### 10.1 Layout Guidelines

Figure 10-1 shows a board layout example for the ADS7066. Avoid crossing digital lines with the analog signal path and keep the analog input signals and the reference input signals away from noise sources.

Use 1- $\mu$ F ceramic bypass capacitors in close proximity to the analog (AVDD) and digital (DVDD) power-supply pins. Avoid placing vias between the AVDD and DVDD pins and the bypass capacitors. Connect all ground pins to the ground plane using short, low-impedance paths.

Place the reference decoupling capacitor ( $C_{REF}$ ) close to the device REF and GND pins. Avoid placing vias between the REF pin and the bypass capacitors.

The charge-kickback RC filters are placed close to the device. Among ceramic surface-mount capacitors, COG- or NPO-type ceramic capacitors provide the best capacitance precision. The type of dielectric used in COG- or NPO-type ceramic capacitors provides the most stable electrical properties over voltage, frequency, and temperature changes.

### 10.2 Layout Example

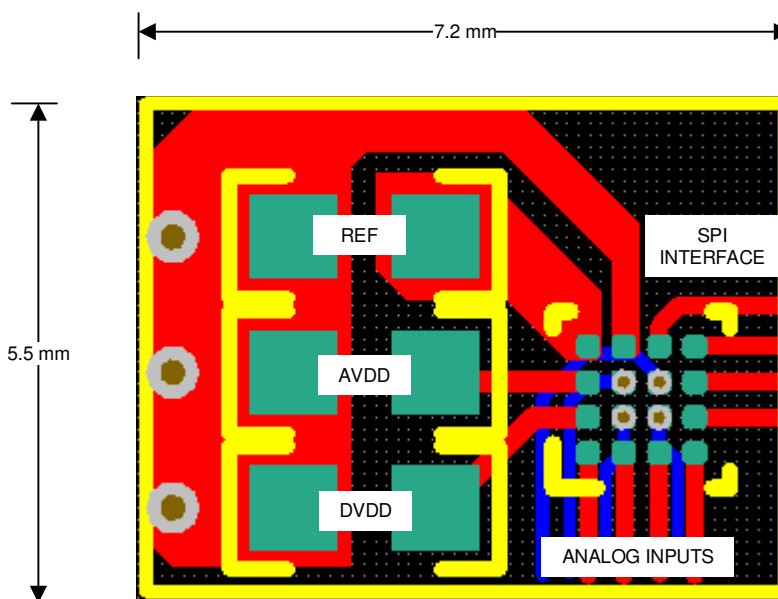

Figure 10-1. Example Layout

## 11 Device and Documentation Support

### 11.1 Device Support

#### 11.1.1 Development Support

Texas Instruments, [ADC Precision Labs](#)

### 11.2 Documentation Support

#### 11.2.1 Related Documentation

For related documentation see the following:

- Texas Instruments, [REF60xx High-Precision Voltage Reference With Integrated ADC Drive Buffer data sheet](#)
- Texas Instruments, [OPAx325 Precision, 10-MHz, Low-Noise, Low-Power, RRIO, CMOS Operational Amplifiers data sheet](#)

### 11.3 Receiving Notification of Documentation Updates

To receive notification of documentation updates, navigate to the device product folder on ti.com. In the upper right corner, click on *Alert me* to register and receive a weekly digest of any product information that has changed. For change details, review the revision history included in any revised document.

### 11.4 Support Resources

[TI E2E™ support forums](#) are an engineer's go-to source for fast, verified answers and design help — straight from the experts. Search existing answers or ask your own question to get the quick design help you need.

Linked content is provided "AS IS" by the respective contributors. They do not constitute TI specifications and do not necessarily reflect TI's views; see TI's [Terms of Use](#).

### 11.5 Trademarks

TI E2E™ is a trademark of Texas Instruments.

All trademarks are the property of their respective owners.

### 11.6 Electrostatic Discharge Caution



This integrated circuit can be damaged by ESD. Texas Instruments recommends that all integrated circuits be handled with appropriate precautions. Failure to observe proper handling and installation procedures can cause damage.

ESD damage can range from subtle performance degradation to complete device failure. Precision integrated circuits may be more susceptible to damage because very small parametric changes could cause the device not to meet its published specifications.

### 11.7 Glossary

[TI Glossary](#) This glossary lists and explains terms, acronyms, and definitions.

## 12 Mechanical, Packaging, and Orderable Information

The following pages include mechanical, packaging, and orderable information. This information is the most current data available for the designated devices. This data is subject to change without notice and revision of this document. For browser-based versions of this data sheet, refer to the left-hand navigation.

**PACKAGING INFORMATION**

Orderable Device	Status (1)	Package Type	Package Drawing	Pins	Package Qty	Eco Plan (2)	Lead finish/ Ball material (6)	MSL Peak Temp (3)	Op Temp (°C)	Device Marking (4/5)	Samples
ADS7066IYBHR	ACTIVE	DSBGA	YBH	16	3000	RoHS & Green	SNAGCU	Level-1-260C-UNLIM	-40 to 125	ADS7066	<a href="#">Samples</a>
ADS7066IYBHT	ACTIVE	DSBGA	YBH	16	250	RoHS & Green	SNAGCU	Level-1-260C-UNLIM	-40 to 125	ADS7066	<a href="#">Samples</a>

(1) The marketing status values are defined as follows:

**ACTIVE:** Product device recommended for new designs.

**LIFEBUY:** TI has announced that the device will be discontinued, and a lifetime-buy period is in effect.

**NRND:** Not recommended for new designs. Device is in production to support existing customers, but TI does not recommend using this part in a new design.

**PREVIEW:** Device has been announced but is not in production. Samples may or may not be available.

**OBsolete:** TI has discontinued the production of the device.

(2) **RoHS:** TI defines "RoHS" to mean semiconductor products that are compliant with the current EU RoHS requirements for all 10 RoHS substances, including the requirement that RoHS substance do not exceed 0.1% by weight in homogeneous materials. Where designed to be soldered at high temperatures, "RoHS" products are suitable for use in specified lead-free processes. TI may reference these types of products as "Pb-Free".

**RoHS Exempt:** TI defines "RoHS Exempt" to mean products that contain lead but are compliant with EU RoHS pursuant to a specific EU RoHS exemption.

**Green:** TI defines "Green" to mean the content of Chlorine (Cl) and Bromine (Br) based flame retardants meet JS709B low halogen requirements of <=1000ppm threshold. Antimony trioxide based flame retardants must also meet the <=1000ppm threshold requirement.

(3) MSL, Peak Temp. - The Moisture Sensitivity Level rating according to the JEDEC industry standard classifications, and peak solder temperature.

(4) There may be additional marking, which relates to the logo, the lot trace code information, or the environmental category on the device.

(5) Multiple Device Markings will be inside parentheses. Only one Device Marking contained in parentheses and separated by a "~" will appear on a device. If a line is indented then it is a continuation of the previous line and the two combined represent the entire Device Marking for that device.

(6) Lead finish/Ball material - Orderable Devices may have multiple material finish options. Finish options are separated by a vertical ruled line. Lead finish/Ball material values may wrap to two lines if the finish value exceeds the maximum column width.

**Important Information and Disclaimer:**The information provided on this page represents TI's knowledge and belief as of the date that it is provided. TI bases its knowledge and belief on information provided by third parties, and makes no representation or warranty as to the accuracy of such information. Efforts are underway to better integrate information from third parties. TI has taken and continues to take reasonable steps to provide representative and accurate information but may not have conducted destructive testing or chemical analysis on incoming materials and chemicals. TI and TI suppliers consider certain information to be proprietary, and thus CAS numbers and other limited information may not be available for release.

In no event shall TI's liability arising out of such information exceed the total purchase price of the TI part(s) at issue in this document sold by TI to Customer on an annual basis.



**TAPE AND REEL INFORMATION**

**QUADRANT ASSIGNMENTS FOR PIN 1 ORIENTATION IN TAPE**



\*All dimensions are nominal

Device	Package Type	Package Drawing	Pins	SPQ	Reel Diameter (mm)	Reel Width W1 (mm)	A0 (mm)	B0 (mm)	K0 (mm)	P1 (mm)	W (mm)	Pin1 Quadrant
ADS7066IYBHR	DSBGA	YBH	16	3000	180.0	8.4	1.8	1.8	0.52	4.0	8.0	Q1
ADS7066IYBHT	DSBGA	YBH	16	250	180.0	8.4	1.8	1.8	0.52	4.0	8.0	Q1

**TAPE AND REEL BOX DIMENSIONS**

\*All dimensions are nominal

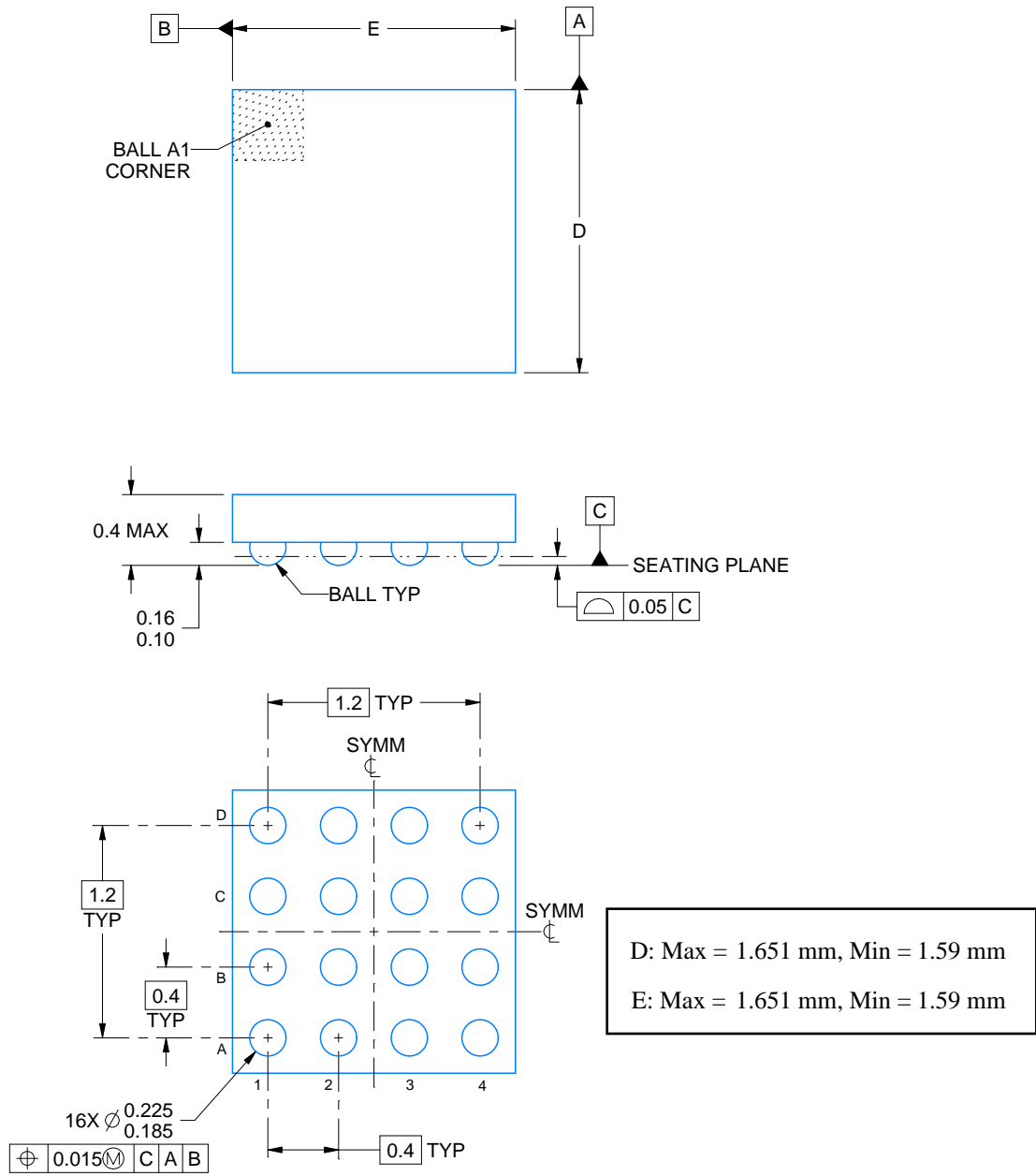
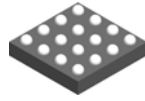
Device	Package Type	Package Drawing	Pins	SPQ	Length (mm)	Width (mm)	Height (mm)
ADS7066IYBHR	DSBGA	YBH	16	3000	182.0	182.0	20.0
ADS7066IYBHT	DSBGA	YBH	16	250	182.0	182.0	20.0



4225022/A 06/2019

NOTES:

1. All linear dimensions are in millimeters. Any dimensions in parenthesis are for reference only. Dimensioning and tolerancing per ASME Y14.5M.
2. This drawing is subject to change without notice.

# EXAMPLE BOARD LAYOUT

YBH0016

DSBGA - 0.4 mm max height

DIE SIZE BALL GRID ARRAY

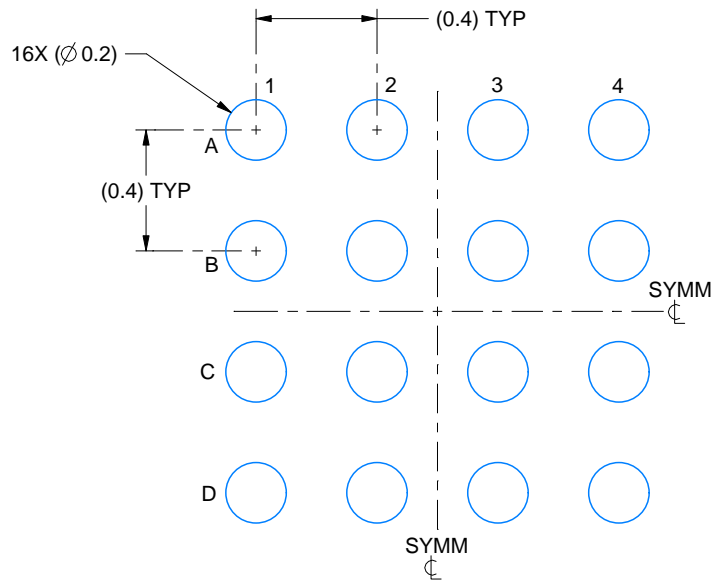

LAND PATTERN EXAMPLE  
EXPOSED METAL SHOWN  
SCALE: 40X

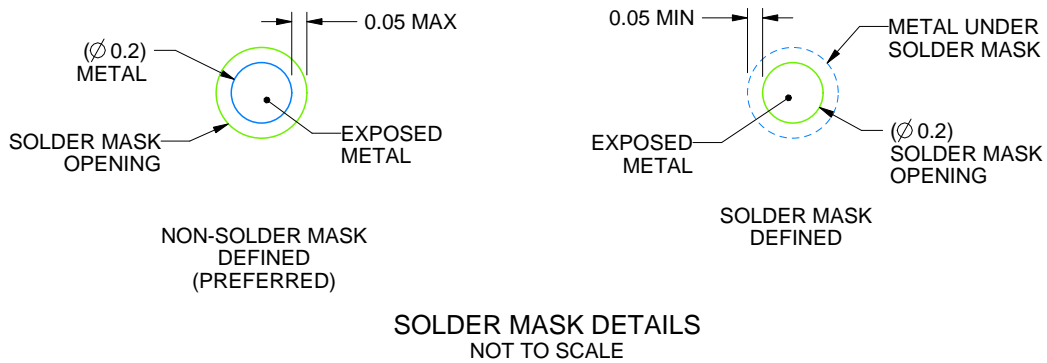

SOLDER MASK DETAILS  
NOT TO SCALE

4225022/A 06/2019

NOTES: (continued)

- Final dimensions may vary due to manufacturing tolerance considerations and also routing constraints. See Texas Instruments Literature No. SNVA009 ([www.ti.com/lit/snva009](http://www.ti.com/lit/snva009)).

# EXAMPLE STENCIL DESIGN

YBH0016

DSBGA - 0.4 mm max height

DIE SIZE BALL GRID ARRAY

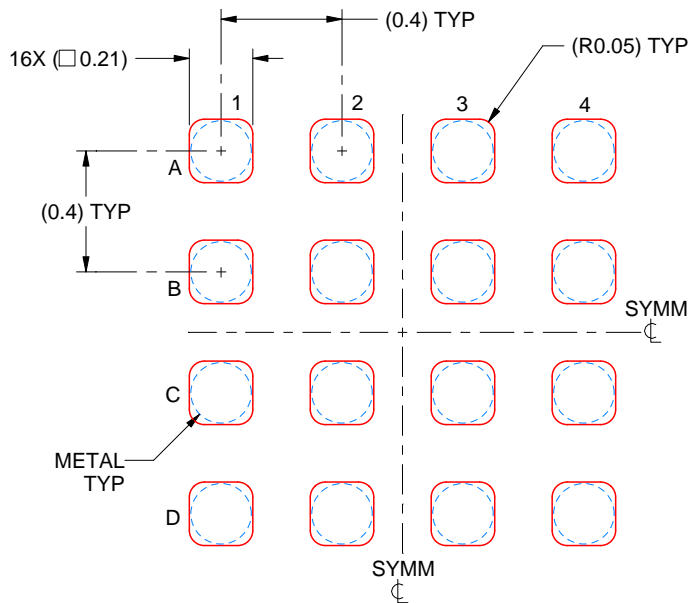

SOLDER PASTE EXAMPLE  
BASED ON 0.075 mm THICK STENCIL  
SCALE: 40X

4225022/A 06/2019

NOTES: (continued)

4. Laser cutting apertures with trapezoidal walls and rounded corners may offer better paste release.

## IMPORTANT NOTICE AND DISCLAIMER

TI PROVIDES TECHNICAL AND RELIABILITY DATA (INCLUDING DATA SHEETS), DESIGN RESOURCES (INCLUDING REFERENCE DESIGNS), APPLICATION OR OTHER DESIGN ADVICE, WEB TOOLS, SAFETY INFORMATION, AND OTHER RESOURCES "AS IS" AND WITH ALL FAULTS, AND DISCLAIMS ALL WARRANTIES, EXPRESS AND IMPLIED, INCLUDING WITHOUT LIMITATION ANY IMPLIED WARRANTIES OF MERCHANTABILITY, FITNESS FOR A PARTICULAR PURPOSE OR NON-INFRINGEMENT OF THIRD PARTY INTELLECTUAL PROPERTY RIGHTS.

These resources are intended for skilled developers designing with TI products. You are solely responsible for (1) selecting the appropriate TI products for your application, (2) designing, validating and testing your application, and (3) ensuring your application meets applicable standards, and any other safety, security, regulatory or other requirements.

These resources are subject to change without notice. TI grants you permission to use these resources only for development of an application that uses the TI products described in the resource. Other reproduction and display of these resources is prohibited. No license is granted to any other TI intellectual property right or to any third party intellectual property right. TI disclaims responsibility for, and you will fully indemnify TI and its representatives against, any claims, damages, costs, losses, and liabilities arising out of your use of these resources.

TI's products are provided subject to [TI's Terms of Sale](#) or other applicable terms available either on [ti.com](https://www.ti.com) or provided in conjunction with such TI products. TI's provision of these resources does not expand or otherwise alter TI's applicable warranties or warranty disclaimers for TI products.

TI objects to and rejects any additional or different terms you may have proposed.

Mailing Address: Texas Instruments, Post Office Box 655303, Dallas, Texas 75265  
Copyright © 2023, Texas Instruments Incorporated